

Alaska Scientific Crime Detection Laboratory

Alaska Breath Test Operator and Supervisor Manual

Effective: 9/6/2024

Version: 5.0

Contents

Breath Alcohol Program Contact Information.....	5
Laboratory Mailing Address	5
Program Contact Methods	5
Staff Roles and Contact Methods	5
Abbreviations and Definitions	6
Alaska Breath Alcohol Program	7
Introduction.....	7
Accreditation and Staffing	7
Breath Alcohol Program Responsibilities.....	7
Legal Requirements (from Alaska Criminal and Traffic Law Manual)	7
13 AAC 63.050. Breath test operator certification	7
13 AAC 63.060. Breath test operator recertification	8
13 AAC 63.070. Breath test supervisor certification and duties.....	8
13 AAC 63.080. Breath test supervisor recertification.....	8
Breath Test Instrument Assignment to Agencies.....	9
Agency Responsibilities.....	9
Breath Alcohol Program Website	9
Ethanol	10
Alcohol Proof.....	10
Standard Drinks	10
Unit Conversions	10
Convert Serum and Plasma Results to Whole Blood.....	11
Relationship of Blood Alcohol to Breath Alcohol.....	11
Blood:Breath Ratio Overview.....	11
Breath Measurement Instruments	11
Per Se Limits for Breath and Blood.....	11
Impairing Effects of Ethanol.....	11
Scientific Studies on Alcohol Impairment.....	11
Alcohol in the Human Body	12
Absorption.....	12
Distribution	13

Alaska Scientific Crime Detection Laboratory

Alaska Breath Test Operator and Supervisor Manual

Effective: 9/6/2024

Version: 5.0

Elimination.....	13
Evidential Breath Test Instrument	14
General Features	14
External Features	14
Home Screen.....	15
DMT Icon Menus.....	17
Setup (F3).....	17
Functions.....	18
Reports (F2)	18
Subject Test (F1).....	19
Supervisor Test (F5)	19
Diagnostic Test (F4)	19
Technician Mode (F7).....	19
VOC Test	19
Tank Change (F8)	19
Linearity (F9).....	19
Security	19
Help.....	19
Subject Test Setup Options.....	19
Printer.....	20
Analytical Principles.....	20
DataMaster DMT Systems Overview.....	20
Optical System	20
Breath/Airflow System	21
Electronic System	23
Subject Tests	24
Pre-Test Procedures	24
Instrument Preparation.....	24
Subject Test Sequence	24
Data Entry	24
Diagnostic Check	25
Purging and Ambient Testing.....	25
Ambient Zeroing.....	25

Alaska Scientific Crime Detection Laboratory

Alaska Breath Test Operator and Supervisor Manual

Effective: 9/6/2024

Version: 5.0

Blank Test.....	25
Internal Standard Check.....	25
External Standard.....	25
Please Blow (Subject Sample).....	25
Remaining Subject Test Steps	25
Signature	26
Test Saved and Printed.....	26
Subject Test Records.....	26
Subject Test Printout and Graph.....	26
Sample Acceptance Parameters	27
Non-Completed Tests	28
External Standards	28
External Standard is Exhausted	28
Replacing the External Standard.....	28
External Standard Traceability	29
Receiving New External Standards	29
Quality Assurance.....	30
Types and Functions of Quality Assurance Measures.....	30
Diagnostic Check.....	30
Blank Test.....	30
Internal Standard.....	30
External Standard.....	30
Verification of Calibration (VOC).....	30
Breath Test Supervisor Duties	32
Overview.....	32
Breath Test Equipment Transportation.....	32
Shipments to Agencies.....	32
Shipments to the Crime Lab	32
Disposal of External Standards.....	33
DataMaster DMT Setup.....	33
Initial Setup.....	33
Select Settings.....	33
Instrument Date and Time	33

Alaska Scientific Crime Detection Laboratory

Alaska Breath Test Operator and Supervisor Manual

Effective: 9/6/2024

Version: 5.0

Instrument Location	34
Operator Training.....	34
Training Overview	34
Operator Training Materials	34
Operator Course Creation	34
Operator Course Completion	35
Supervisor Paperwork.....	35
Overview.....	35
Change in Instrument Status Form	35
Change in Operator Status Form.....	35
Ordering Breath Alcohol Testing Supplies.....	36
Overview and Agency Responsibilities	36
Types and Sources of Supplies	36
Status Messages and Troubleshooting.....	37
Overview.....	37
When a Status Message Occurs	37
Status Message Descriptions.....	37
Ambient Fail	37
Maximum Attempts Exceeded.....	37
Incomplete.....	37
Invalid	38
Interference (Subject Sample).....	38
Interference (External Standard).....	38
Subject Sample Displays XXX.....	38
RFI Detected	38
Standard Out of Range.....	38
Troubleshooting Suggestions.....	39
References.....	43
Status and Test Codes	44
Revision History	45

Alaska Scientific Crime Detection Laboratory

Alaska Breath Test Operator and Supervisor Manual

Effective: 9/6/2024

Version: 5.0

Breath Alcohol Program Contact Information

Laboratory Mailing Address

Alaska Scientific Crime Detection Laboratory
Attn: Breath Alcohol Program
4805 Dr. Martin Luther King Junior Avenue
Anchorage, AK 99507
(907) 269-5740

Program Contact Methods

Program E-mail

dps.scdl.toxicology@alaska.gov

Alaska Breath Alcohol Program Website

[https://dps.alaska.gov/Statewide/CrimeLab/DataMaster-\(1\)/datamaster](https://dps.alaska.gov/Statewide/CrimeLab/DataMaster-(1)/datamaster)

Staff Roles and Contact Methods

Derek Walton, Forensic Scientist 4

Scientific Director of the Breath and Blood Alcohol Testing Program

Derek.Walton@Alaska.gov

(907) 269-5628

Carlie Glaister, Forensic Scientist 3

Carlie.Glaister@Alaska.gov

(907) 269-5689

Colleen O'Bryant, Forensic Scientist 3

Colleen.OBryant@Alaska.gov

(907) 269-5783

Kaija Swisher, Forensic Scientist 2

Kaija.Swisher@Alaska.gov

(907) 269-5535

Megan Carlock, Forensic Scientist 2

Megan.Carlock@Alaska.gov

(907) 269-3005

Paulyne Catacutan, Forensic Technician

Paulyne.Catacutan@Alaska.gov

(907) 269-3746

Alaska Scientific Crime Detection Laboratory

Alaska Breath Test Operator and Supervisor Manual

Effective: 9/6/2024

Version: 5.0

Abbreviations and Definitions

AAC:	Alaska Administrative Code
ABV:	Alcohol by volume, a measure of alcohol concentration
ANAB:	ANSI National Accreditation Board
ANSI:	American National Standard Institute
APSC:	Alaska Police Standards Council
ASB:	Academy Standards Board, a part of the American Academy of Forensic Sciences
BTO:	Breath Test Operator
BTS:	Breath Test Supervisor
DMT:	DataMaster Transportable, a part of the product name: DataMaster DMT
DPS:	Alaska Department of Public Safety
DUI:	Driving under the influence
g/100 mL:	Grams per 100 milliliters, a common unit of blood alcohol concentration
g/210 L:	Grams per 210 liters, a common unit of breath alcohol concentration
g/dL:	Grams per deciliter, a unit of blood alcohol concentration; Equal to g/100mL
ISO:	International Organization for Standardization
L:	Liters, a unit of volume as displayed on the subject test strip
L/M:	Liter per minute, a unit of flow as displayed on the subject test strip
mg/dL:	Milligrams per deciliter, a unit of blood alcohol concentration, Equal to 1000 times g/100mL
mL:	Milliliter, a unit of volume
NPAS:	National Patent Analytical System, the original manufacturer of the DataMaster DMT product
Proof:	A measure of alcohol concentration; Equal to twice the ABV
PSI/psi:	Pounds per square inch, a measure of pressure
RFI:	“Radio Frequency Interference detected”, an instrument status message
TBW:	Total Body Water, a measure of the amount of water in a particular person’s body
VOC:	Verification of Calibration, a check of the accuracy of deployed instruments performed at least every 60 days

Alaska Scientific Crime Detection Laboratory

Alaska Breath Test Operator and Supervisor Manual

Effective: 9/6/2024

Version: 5.0

Alaska Breath Alcohol Program

Introduction

NOTE: This manual is intended to be a training guide for Alaska breath test operators and supervisors using approved evidential breath test instruments. It is NOT a comprehensive guide for impaired driving/DUI processing. Officers should use this to supplement agency policies and procedures.

If any content in this manual is unclear, please contact a local Breath Test Supervisor or the Alaska State Crime Lab using the [Breath Alcohol Program Contact Information](#).

Accreditation and Staffing

The breath alcohol program (also known as Forensic Toxicology – Calibration) is a forensic service provided by the Crime Lab. The breath alcohol program is accredited under ANAB ISO 17025 as a calibration laboratory.

The program consists of the Scientific Director of the breath and blood alcohol testing program, Forensic Scientists, and Forensic Technicians who operate within the laboratory Quality Assurance Program.

Breath Alcohol Program Responsibilities

The duties of the breath alcohol program include breath test instrument calibration, adjustment, and maintenance; administration of records; training, opinions and interpretations, and court testimony.

The breath program provides training to law enforcement officers through instruction of the Breath Test Supervisor course. The breath program also creates training content to be provided to prospective Breath Test Operators via instruction from Breath Test Supervisors. Breath Test Supervisors have primary responsibility for providing training to Breath Test Operators in their local area.

Legal Requirements (from Alaska Criminal and Traffic Law Manual)

The following legal requirements apply to the certification and recertification of Breath Test Operators (BTO) and Breath Test Supervisors (BTS) in the state of Alaska. The text is current as of the effective date of this laboratory Manual.

13 AAC 63.050. Breath test operator certification

(a) To be certified as an operator of a breath test instrument, an applicant must successfully complete a course of instruction approved by the scientific director. The course must include at least four hours of instruction in the theory of alcohol physiology, toxicology, pharmacology, instrument maintenance, practical operation, and administrative procedures. The applicant must also obtain a score of 75 percent or higher on a written examination, approved by the scientific director, covering the content of the course.

(b) The scientific director shall, in his or her discretion, issue an operator certificate and operator identification number to an applicant upon receipt of written notice from a supervisor that the applicant has successfully completed a course of training and examination that meets the requirements of this section. An operator certificate expires at 11:59 p.m. on December 31 of the third year after the year issued.

Alaska Scientific Crime Detection Laboratory

Alaska Breath Test Operator and Supervisor Manual

Effective: 9/6/2024

Version: 5.0

13 AAC 63.060. Breath test operator recertification

(a) To renew a breath test operator's certification, a breath test operator must, during the period of the operator's current certification,

(1) complete a refresher course approved by the scientific director that includes at least four hours of instruction and training; and

(2) obtain a score of 75 percent or higher on a written examination, approved by the scientific director, covering the content of the refresher course.

(b) The breath test supervisor shall submit a written notice to the scientific director that an operator seeking to renew a breath test operator's certificate has complied with the requirements of (a) of this section. Upon receipt of the notice, the scientific director shall renew the breath test operator certificate and operator identification number.

(c) A breath test operator certificate that has been renewed under this section expires at 11:59 p.m. on December 31 of the third year after the year issued.

13 AAC 63.070. Breath test supervisor certification and duties

(a) To be certified as a breath test supervisor, an applicant must

(1) complete a 22-hour supervisor training course approved by the scientific director; the course must include instruction in the theory of alcohol physiology, pharmacology, toxicology, instrument function, instrument maintenance, practical operation, administrative procedures, legal considerations, and other pertinent subjects as required by the scientific director;

(2) possess a valid instructor's certificate issued by the Alaska Police Standards Council under 13 AAC 87.040; and

(3) obtain a score of 75 percent or higher on a written examination, approved by the scientific director, covering the content of the training course.

(b) The scientific director shall issue a breath test supervisor certificate and an identification number to an applicant if the applicant has met the requirements of (a) of this section. A breath test supervisor certificate expires at 11:59 p.m. on December 31 of the third year after the year issued.

(c) In addition to performing all the duties of an operator, a breath test supervisor may train breath test operators and perform routine maintenance on a breath test instrument. A supervisor certificate is also an operator's certificate.

(d) A breath test supervisor shall inform the scientific director of the location of breath test instruments and the status of breath test operators under the breath test supervisor's supervision.

13 AAC 63.080. Breath test supervisor recertification

(a) To renew a breath test supervisor's certification, a supervisor must, during the period of the supervisor's current certification,

(1) complete a refresher course approved by the scientific director that includes at least 15 hours of instruction and training; and

(2) obtain a score of 75 percent or higher on a written examination, approved by the scientific director, covering the content of the refresher course.

(b) If the breath test supervisor has met the requirements of (a) of this section, that supervisor may request in writing a renewed certificate from the scientific director. Upon receipt of the request, the scientific director shall renew the certificate.

(c) A breath test supervisor certificate that is renewed under this section expires at 11:59 p.m. on December 31 of the third year after the year issued.

Alaska Scientific Crime Detection Laboratory

Alaska Breath Test Operator and Supervisor Manual

Effective: 9/6/2024

Version: 5.0

These requirements outline the requirements for training and examination, issuing of BTO or BTS certificates and the expiration timeline of said certificates, the roles and responsibilities of Breath Test Supervisors, and the documentation supporting the occurrence of BTO and BTS training.

Breath Test Instrument Assignment to Agencies

Evidential breath test instruments are the property of the State of Alaska. Limited exceptions exist where agencies own their own instrument. The Scientific Director entrusts State-owned instruments to approved agencies contingent on their responsible care and use. The lab will provide functional instruments to each approved location and supply approved external standard tanks, as needed.

The Scientific Director reserves the right to remove any State-owned instrument from an agency if the [Agency Responsibilities](#) are not being met. The Scientific Director reserves the right to revoke the Calibration of any instrument maintained under the State of Alaska Breath Alcohol Program at any time. The Scientific Director must notify an agency in writing of either of these decisions and the justification no later than the time of occurrence.

Agency Responsibilities

Breath Test Supervisors are responsible for day-to-day operation and upkeep of the instruments at their location and are accountable for problems arising from neglect and/or misuse. Agencies are responsible for maintaining a current BTS for each instrument location, although one BTS may supervise multiple locations in close proximity. If a BTS is temporarily not available at an agency, the agency is responsible for designating a point of contact (preferably a trained BTO) to communicate with the Crime Lab until such time as an officer is certified as a BTS to serve that location.

Additionally, agencies are expected to:

- Protect and securely store State-issued instruments
- Maintain and operate the instrument in accordance with the Breath Alcohol Program requirements in this document
- Connect the instrument to a functioning analog modem line. The line must be:
 - Dedicated to the DataMaster and no other devices
 - Data-capable (like a fax machine)
- Promptly communicate with the Crime Lab to report instrument issues or respond to Crime Lab communication

Breath Alcohol Program Website

The Alaska State Crime Lab website has a designated page for breath alcohol program information: [Datamaster - DataMaster - CrimeLab - Alaska Department of Public Safety](#).

The website is the best place to locate current Breath Test Operator training materials, controlled forms such as the Change in Instrument Status form, and a great deal of discovery information such as Verification of Calibration (VOC) records and current lists of trained operators in the State of Alaska.

Alaska Scientific Crime Detection Laboratory

Alaska Breath Test Operator and Supervisor Manual

Effective: 9/6/2024

Version: 5.0

Ethanol

Ethanol (or ethyl alcohol) is the chemical name for the alcohol commonly consumed in alcoholic beverages. In this document, “ethanol” and “alcohol” are used interchangeably. Ethanol is a small, water-soluble molecule readily absorbed by the human body and distributed by the blood throughout all the water-containing components of the body.

Alcohol Proof

Proof indicates the concentration of an alcoholic beverage. The concentration of alcohol in “percent by volume” (%v/v) is one half of the proof value.

$$\frac{80 \text{ Proof}}{2} = 40 \%v/v$$

Common abbreviations for alcohol percent by volume are ABV and % (v/v). The volume of pure ethanol may be converted to its mass using ethanol’s density.

$$1 \text{ mL ethanol} = 0.789 \text{ grams ethanol}$$

Standard Drinks

The term “standard drink” applies to drinks of “standard” alcoholic strength. In the United States, a standard drink is officially defined as containing the equivalent of 14 grams of ethanol.¹ The resulting concentration of ethanol (% v/v) when 14 grams of pure ethanol is diluted to a given volume can be calculated as follows:

$$\text{Concentration in ABV} = \frac{(100 \times 14 \text{ grams})}{(\text{Volume of drink in ounces} \times 29.6 \frac{\text{mL}}{\text{ounce}} \times 0.789 \frac{\text{grams ethanol}}{\text{mL}})}$$

This equation means that the following beverages meet the definition of a standard drink in the United States (each contains 14 grams of alcohol):

- 12 ounces of 5% (v/v) beer
- 5 ounces of 12% (v/v) wine
- 1.5 ounces of 40% (v/v) spirits (80 Proof)

Unit Conversions

The Crime Lab reports blood alcohol concentrations in units of “grams per 100 milliliters” (g/100mL). Other laboratories may use the units of “grams per deciliter” (g/dL). Because one deciliter equals 100 milliliters, these units are equivalent.

$$\text{Example: } 0.080 \text{ g/100mL} = 0.080 \text{ g/dL}$$

Alcohol concentrations reported in medical results are commonly in units of “milligrams per deciliter” abbreviated mg/dL. Because one gram equals 1000 milligrams, mg/dL can be converted to g/dL by dividing by 1000.

$$\text{Example: } 80 \text{ mg/dL} = 0.080 \text{ g/dL} = 0.080 \text{ g/100mL}$$

Alaska Scientific Crime Detection Laboratory

Alaska Breath Test Operator and Supervisor Manual

Effective: 9/6/2024

Version: 5.0

Convert Serum and Plasma Results to Whole Blood

Hospital reports often list alcohol concentrations as being from blood; however, serum or plasma is commonly the sample analyzed. Serum is the liquid that remains when blood is collected without an anticoagulant and allowed to clot. Plasma is the liquid separated from whole blood and treated with an anticoagulant when the blood cells are removed.

Because serum/plasma are the water portion of whole blood, they each have a higher alcohol content per volume than the whole blood from which they originated. The average ratio of serum and plasma alcohol content to whole blood alcohol content is 1.14:1 with a range of 1.04:1 to 1.26:1.²

The whole blood alcohol concentration may be estimated from the reported serum/plasma alcohol concentration using the average ratio:

$$\text{Whole Blood Alcohol Content} = \frac{\text{Serum/Plasma Alcohol Content}}{1.14}$$

Relationship of Blood Alcohol to Breath Alcohol

Blood:Breath Ratio Overview

Breath alcohol instruments indirectly estimate a person's blood alcohol concentration using an correction factor called the "blood:breath ratio". The ratio describes how the concentration of alcohol in someone's venous blood relates to the concentration of alcohol in their deep lung air.

Breath Measurement Instruments

Breath instruments in the United States assume a blood/breath ratio of 2100:1. Studies have shown that the blood/breath ratio can be less than 2000:1 during the absorptive phase, increasing to about 2100:1 by 90 minutes post -dosing (after alcohol consumption), and further increasing to 2300:1 or 2400:1 later in the post-absorptive phase.³

Per Se Limits for Breath and Blood

Because of the variability in the blood:breath ratio, a breath alcohol result should not be converted to a blood alcohol concentration. Despite this variability, breath and blood alcohol testing are both valid when determining current alcohol content. The AAC lists the legal limit of 0.08 in **both** blood (g/100mL) and breath (g/210L) units.⁴ This makes direct conversion between the two unnecessary.

Impairing Effects of Ethanol

Ethanol is a central nervous system depressant. The magnitude of depressant effects depends on the amount of ethanol consumed (i.e., more ethanol = more severe effects). Depressant effects of alcohol may lead to increased reaction time (decreased information processing rate), decreased/impaired judgment, and decreased coordination/multi-tasking.

Scientific Studies on Alcohol Impairment

Scientific studies compared the relative vehicle crash risk of people with a specific alcohol level to people with no alcohol in their system.^{5,6} Relative crash risk asks the question, "What are the odds of a person getting in an accident at a particular BAC compared to the odds of a person getting in an accident with no alcohol in their system?" The largest of these studies used crash data from Grand Rapids, MI and more recently in Long Beach, CA and Fort Lauderdale, FL.

The authors of the Grand Rapids study concluded that above a 0.08% (w/v) blood alcohol level, factors other than alcohol became less and less significant and eventually seemed to disappear.⁵ This is compelling evidence that alcohol is a major factor in the cause of traffic collisions.

The Committee on Alcohol and Other Drugs of the National Safety Council concluded that all individuals are impaired with respect to operating a motor vehicle at concentrations of 0.08% (w/v) and above. Additionally, some individuals are impaired with respect to driving at concentrations below 0.08 % (w/v).²

Alcohol in the Human Body

After a person consumes alcohol, a graph of the ethanol concentration can be divided into three phases: Absorptive, Peak, and Post-Absorptive. See Figure 1.

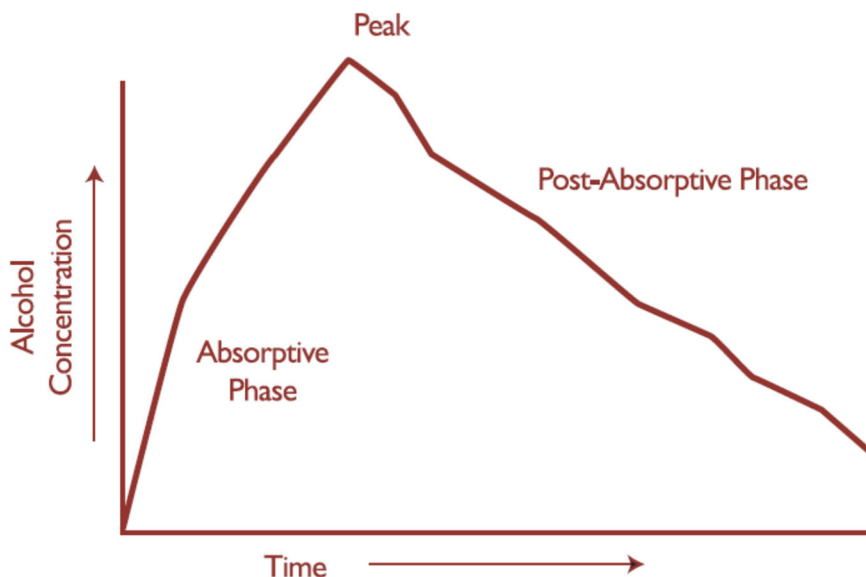

Figure 1: General alcohol concentration curve

As soon as alcohol is absorbed, the body begins to eliminate it. During the Absorptive Phase, the alcohol concentration is increasing at a faster rate than it is being eliminated leading to an overall increase. At the Peak alcohol concentration, absorption and elimination rates are equal. In the Post-Absorptive phase, absorption of alcohol is complete and the concentration will decrease until it is eliminated.

Absorption

When alcohol is ingested, about 20-25% is absorbed through the stomach lining. The remaining 75-80% is absorbed when the alcohol reaches the small intestine through the valve in the bottom of the stomach.²

The most crucial factor affecting the rate of absorption is whether food is in the stomach at the same time as the alcohol. Peak concentrations are generally attained within 30 to 60 minutes of

Alaska Scientific Crime Detection Laboratory

Alaska Breath Test Operator and Supervisor Manual

Effective: 9/6/2024

Version: 5.0

the cessation of drinking.² When alcohol is consumed over time (“social drinking”), the peak may occur within 30 minutes of the last drink or even before the last drink is finished.²

Distribution

Alcohol is completely water soluble; therefore, the alcohol concentration in the body after an alcohol dose is related to the person’s Total Body Water (TBW) content. The greater the body water, the less concentrated the alcohol will be after distribution. Approximately 68% of an average male’s body weight is due to water. For an average female, the percentage is ~55%.²

Elimination

The majority of humans eliminate alcohol between 0.010 g/100mL/hr and 0.025 g/100mL/hr with an average of 0.017 g/100mL/hr.³

Factors influencing individual elimination rates may include how well-nourished the person is and whether continuous drinking has occurred over a period of several days.³ Individual elimination rates may vary. Rather than speculating over a specific elimination rate at a given time, a range of elimination rates are used.³

Evidential Breath Test Instrument

The current approved breath test instrument in the State of Alaska is the DataMaster DMT. This instrument was originally manufactured by National Patent Analytical Systems (NPAS), but is now manufactured by Intoximeters, Inc. under the product name “Intox DMT”.

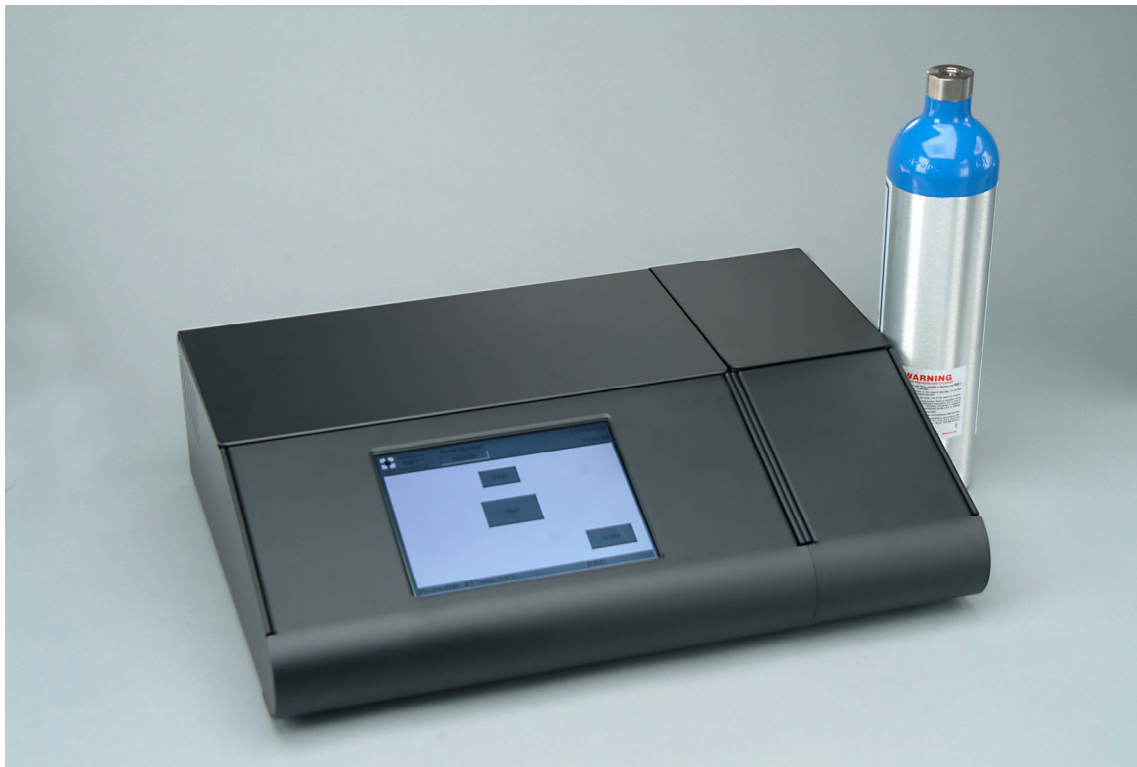

Image 1: DataMaster DMT with dry gas external standard tank..

General Features

The analytical features of the DataMaster DMT include a thermo-electrically-cooled infrared detector, a folded optical path, a 28 mL sample cell volume, narrow bandwidth optical filters, a gray body infrared source, and a mass air flow sensor. Other internal and software features include: an internal quartz standard of known and constant absorbance for repeated verification of calibration, a single point adjustment process, a sealed detection system, a three-filter optical system for detecting interfering compounds, levels of password security, and a radio frequency interference (RFI) detection system (DMT Product Overview, 2010).

External Features

External features of the DataMaster DMT include heated breath hose and simulator tubes, a dry gas tank storage compartment with an automated internal regulator, modem, Ethernet, and USB ports, full color touch screen LCD display, calibration port, and Radio Frequency (RF) protection through shielding (black coated aluminum housing). The LCD touchscreen allows the user to operate the software and displays popup messages to assist in instrument operation. See images 1 and 2.

Alaska Scientific Crime Detection Laboratory

Alaska Breath Test Operator and Supervisor Manual

Effective: 9/6/2024

Version: 5.0



Image 2: Rear Panel of the DataMaster DMT with installed dry gas external standard tank.

Home Screen

The LCD touchscreen is used to operate the instrument with an attached external keyboard for data entry. Icons and menus allow initiation of all tests and changing the setup of the instrument, with appropriate password entry.

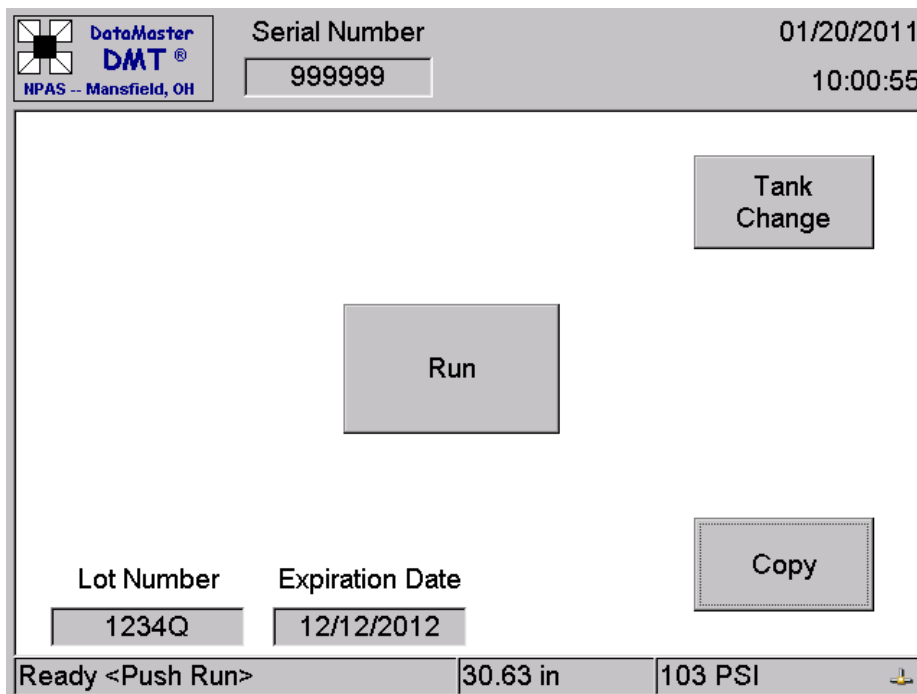

Image 3: Software Home Screen of DataMaster DMT

To begin, the user will touch the display to bring up the Home Screen (see Image 3). This screen consists of four icons as well as various status indicators. The active icons are:

- DMT Icon – Located in the upper left-hand corner
 - Displays a drop-down menu with all instrument functions. Refer to [DMT Icon Menus](#) for a complete list.

Alaska Scientific Crime Detection Laboratory

Alaska Breath Test Operator and Supervisor Manual

Effective: 9/6/2024

Version: 5.0

- RUN – Begins a subject test
- COPY – Prints the last test conducted
 - If “There is nothing to copy” appears, no test has occurred since the instrument was turned On.
- TANK CHANGE – Prompts the user to enter new dry gas external standard identifying information.
 - A VOC is initiated automatically after a tank change.

Status indicators identify conditions of certain instrument components (see Image 3):

- Instrument Status Box – lower left-hand corner
 - During normal operation, displays “Ready <Push Run>”.
 - During warm up, displays a countdown to indicate when the instrument is ready for testing.
 - Displays other as-needed indicators such as Change Tank Soon, Change Tank, and Perform VOC.
- Barometric Pressure – Bottom center, measured in inches of mercury
- Gas Cylinder Pressure – Bottom right-hand corner
 - Displays the external standard tank pressure in psi. This box turns red when the external standard tank pressure is less than 150 psi.
- External Standard Lot Number – Above the Instrument Status Box
 - Displays the lot number of the currently installed external standard.
- External Standard Expiration Date - Above the Instrument Status Box
 - Displays the expiration date of the currently installed external standard. Turns red when the tank expiration is within 30 days.

Alaska Scientific Crime Detection Laboratory

Alaska Breath Test Operator and Supervisor Manual

Effective: 9/6/2024

Version: 5.0

DMT Icon Menus

Touching the DMT Icon in the top left-hand corner, a drop-down menu will appear (see Image 4). Keyboard function keys may be used for selection.

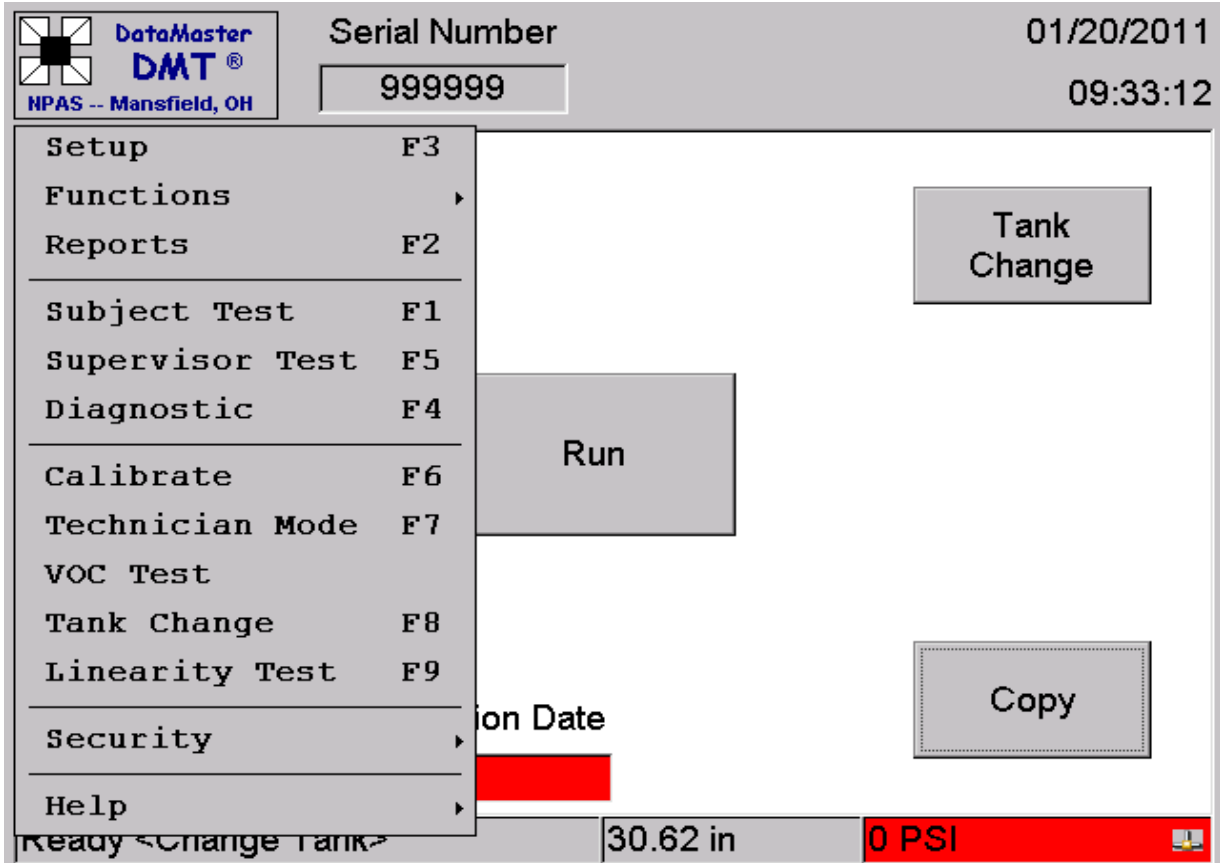

Image 4: DataMaster DMT Icon/Main Menu

Setup (F3)

The Setup menu contains settings for the DMT options. A password must be entered before accessing Setup. The access level determines the categories and options that may be viewed and changed. See Image 5.

Alaska Scientific Crime Detection Laboratory

Alaska Breath Test Operator and Supervisor Manual
Effective: 9/6/2024

Version: 5.0

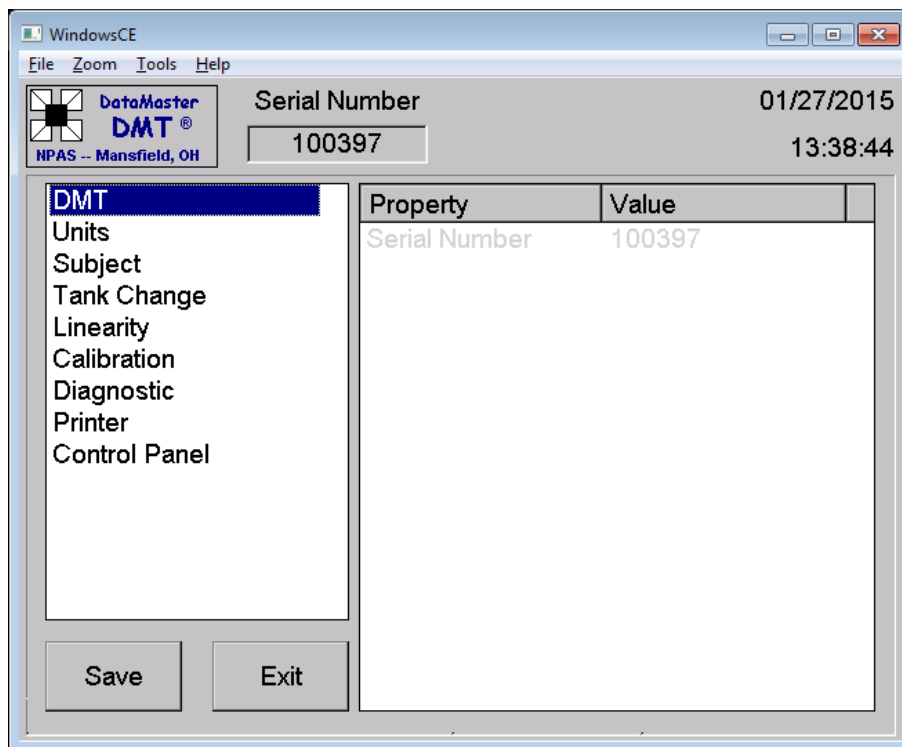

Image 5: Setup (F3) Screen for DataMaster DMT

The options in the Setup screen are discussed below.

- DMT – Contains information on that specific instrument.
 - Editable by the breath program staff or higher security level. Updated after an SI board replacement.
- Units – Lists the units for reporting breath alcohol (g/210 L).
- Subject – Options for the subject test including turning the graph On/Off and the number of printed copies of the test strip.
 - Editable by BTS and above security level. A more detailed description of these options is listed in the Subject Test Setup Options section.
- Tank Change – Options for tank changes
 - Editable by breath program staff or higher security level.
- Printer – Options for the external printer
 - Editable by BTS and above security level
- Control Panel – Options for external devices such as stylus/touchscreen calibration
 - Editable by BTS and above security level

Functions

From this menu, the breath test operator or breath test supervisor can update the date and time display. A breath test supervisor may remove and return the instrument from and to service, export subject test data, and purge the sample chamber.

Reports (F2)

Allows a user to access and print tests stored in memory. This includes prior subject tests, diagnostic tests, supervisor tests, and VOC reports.

Alaska Scientific Crime Detection Laboratory

Alaska Breath Test Operator and Supervisor Manual

Effective: 9/6/2024

Version: 5.0

Subject Test (F1)

Initiates a subject test.

Supervisor Test (F5)

Initiates a supervisor test. This option is used primarily by the breath program staff.

Diagnostic Test (F4)

Initiates a diagnostic check. This option is accessible to breath test operator and higher security levels.

Technician Mode (F7)

Opens the technician screen where a BTS or higher security level may view the internal voltages and settings of the DataMaster DMT. Breath program staff or higher security level is required to adjust these settings.

VOC Test

Breath test operator and higher security levels may initiate a VOC test at any time.

Tank Change (F8)

Guides the breath test operator or higher security level through a dry gas external standard cylinder replacement.

Linearity (F9)

Performs a test of the accuracy of the instrument across different concentrations. This option requires breath program staff or higher security level.

Security

Provides a login prompt to access a higher security level. Requires a password. This option may also be used to sign out of the current security level.

Help

Provides information about the instrument software versions and next automated VOC date.

Subject Test Setup Options

These options are accessed from the DMT Icon (top left-hand corner). Contains the following options:

- Ask Questions: BTS or higher security may turn off data entry (e.g., subject name and operator license) before the subject test. Default is Yes (On). Only changed for training purposes.
- Number of Tests: BTS or higher security may change the number of subject tests in a single subject test sequence. Default is 1. Only changed for training purposes.
- Alcohol Display: BTS or higher security may turn on the real-time display of the subject's ethanol concentration on the bottom of the screen. Default is Yes (On).
- Volume Display: BTS or higher security may turn on the real-time display of the subject's breath volume (for the current attempt) at the bottom of the screen. Default is Yes (On).

Alaska Scientific Crime Detection Laboratory

Alaska Breath Test Operator and Supervisor Manual

Effective: 9/6/2024

Version: 5.0

- Graph Display: BTS or higher security may turn on display of the graph of the subject blow. This is not displayed while the subject is blowing, only after their sample is completed. Default is Yes (On).
- Graph Alcohol: BTS or higher security may turn on a real-time graph of the subject's alcohol concentration on the screen while the subject is blowing. Default is No (Off).
- Graph Flow: BTS or higher security may turn on a real-time graph of the subject's breath flow rate on the screen while the subject is blowing. Default is No (Off).
- Query Refusal: BTS or higher security may turn on a popup window immediately prior to the subject breath sample asking whether the subject refused. If Yes is selected, the strip will print with the subject sample listed as Refused. If No is selected, the subject test will proceed normally. Default is No (query Off).
- Wait Between Tests: Option not used. Default is zero.
- Signature On: BTS or higher security may turn on a signature box appearing at the end of a subject test sequence. If a signature is entered, it will be printed at the bottom of the subject test strip. Default is Yes (On).
- Copies: Determines how many copies of the test strip are printed after a subject test sequence has been completed. Default is 1.

Printer

The DataMaster DMT uses an external laser jet printer. The initial printer is provided by the Crime Lab. Paper, printer cartridges, and replacement printers are the responsibility of the agency. Contact the Crime Lab for more information on replacement parts or printers.

Analytical Principles

The DataMaster DMT uses infrared spectroscopy to measure the level of ethanol in human breath for forensic purposes. Infrared (IR) energy is part of the electromagnetic spectrum. It is measured using specific wavelengths of infrared light expressed as micrometers (μm).

When a chemical molecule is exposed to IR energy, the bonds of the molecule absorb some of that energy. Different atomic bonds absorb different wavelengths of IR energy. The amount of IR energy absorbed by the sample is related to the concentration of ethanol in the sample. The wavelengths used to detect ethanol and check for interfering substances are 3.37 μm , 3.44 μm , and 3.50 μm .

DataMaster DMT Systems Overview

The DataMaster DMT is comprised of three basic systems: the optical system, the breath/airflow system, and the electronic system.

Optical System

The optical system contains the parts of the DataMaster DMT responsible for producing and collecting IR energy to identify and measure the amount of ethanol in a human breath sample. A schematic of these components is pictured in Image 6.

Alaska Scientific Crime Detection Laboratory

Alaska Breath Test Operator and Supervisor Manual

Effective: 9/6/2024

Version: 5.0

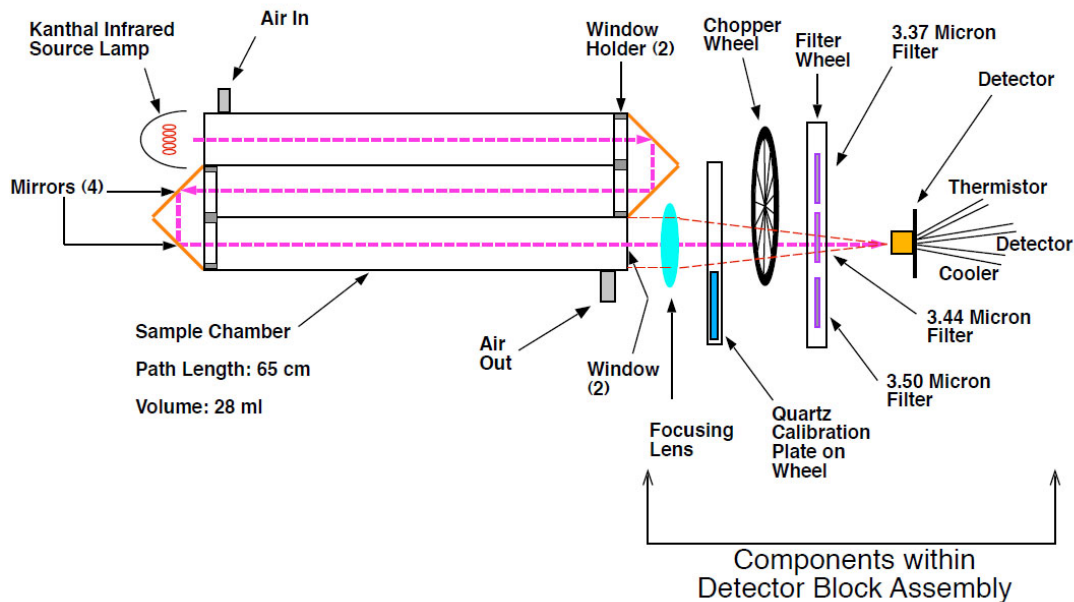

Image 6: DataMaster DMT Optical System Diagram

- Kanthal Infrared Source Lamp – Produces IR energy from electrical current.
- Sample Chamber – Contains the vapor being measured. The sample chamber is heated to approximately 50°C to prevent condensation. The sample chamber is folded to increase the instrument sensitivity.
- Mirrors – Located at the “folds” of the sample chamber to direct IR energy through the system.
- Focusing Lens – Focuses IR energy onto the detector.
- Quartz Calibration Plate on Wheel (Internal Standard) – 1 mm thick quartz; moved into the optical path during the internal standard check.
- Chopper Wheel – Interrupts the IR energy before striking the detector.
- Micron Filters – Filters the IR energy to detect only the desired wavelengths.
- Detector – Absorbs remaining IR energy to determine ethanol vapor content.

Breath/Airflow System

The breath/airflow system allows movement of vapor in and out of the sample chamber and purges the sample chamber with clean room air. The components are pictured in Image 7.

Alaska Scientific Crime Detection Laboratory

Alaska Breath Test Operator and Supervisor Manual

Effective: 9/6/2024

Version: 5.0

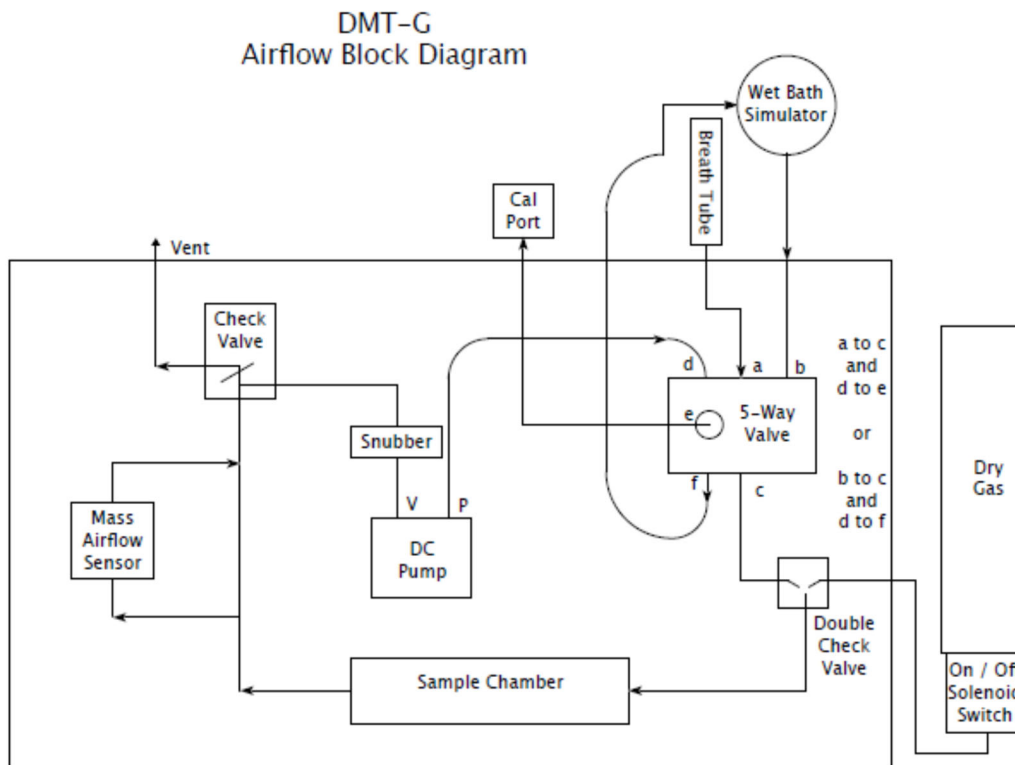

Image 7: DataMaster DMT Airflow Block Diagram

- Internal Tubing (arrows) – The pathway for vapor samples and room air to travel from the breath hose/regulator/simulator, through the sample chamber, and out the outlet ports.
- Breath Tube - Heated to approximately 50°C to prevent condensation
- 5-Way Valve – Internal valve that controls the airflow path via signals sent from the on-board computer.
- Double check value – Prevents airflow back through the dry gas flow path during a breath test and back into the 5-way valve during an external standard test.
- Dry Gas and On/Off Solenoid Switch – A dry gas external standard tank containing a known concentration of ethanol vapor is attached to an electronically-activated internal regulator to open or close the tank at the appropriate time during the test sequence.
- Sample Chamber – Contains the vapor being measured. The sample chamber is heated to approximately 50°C to prevent condensation.
- Mass Airflow Sensor – Measures the flow rate and volume of air passing through the instrument.
- Snubber – Reduces pressure fluctuations due to the action of the DC pump to maintain the check valve position
- DC Pump – Creates a vacuum/pressure that draws or pushes air through the system.
- Cal Port – Used for instrument adjustment by the breath program staff or manufacturer.
- Wet Bath Simulator – Used for functional tests by the breath program staff or manufacturer. This equipment is not used when the instrument is in the field.
- Dry Gas with On/Off Solenoid Switch – Internal automatic regulator that releases gas from the installed external standard tank at the appropriate time via signals from the on-board computer.

Alaska Scientific Crime Detection Laboratory

Alaska Breath Test Operator and Supervisor Manual

Effective: 9/6/2024

Version: 5.0

Electronic System

The electronic system controls the electrical and programmed functions of the instrument. It includes the power supply, onboard computer, and controller board. The interaction of electronic, mechanical, and optical components allow the instrument to function as designed and interact with the user. The DataMaster DMT utilizes a Windows CE operating system in conjunction with Alaska-specific installed software.

Alaska Scientific Crime Detection Laboratory

Alaska Breath Test Operator and Supervisor Manual
Effective: 9/6/2024 Version: 5.0

Subject Tests

It is essential that breath test operators and breath test supervisors follow proper procedures when administering a breath test. The subject should be carefully observed during the breath test sequence so his/her actions, demeanor, and behavior may be documented.

Pre-Test Procedures

Turn off portable radios in the vicinity of the testing area, when possible. This is to avoid the possibility of an RFI DETECTED status message that will abort the subject test sequence. Ensure the testing area is free of solvents and fumes, including vehicle exhaust. When feasible, keep subjects away from the breath test instrument until ready to blow.

13 AAC 63.040, "Procedure for breath test analysis" provides requirements for the 15-minute wait, operation of the instrument, and certification of the breath test operator.

Instrument Preparation

The DataMaster should display READY <Push Run> in the instrument status box. The operator should verify that the time and date display is accurate and correct (see [Functions](#)). The breath test operator will supply a new mouthpiece for each breath testing sequence.

Subject Test Sequence

Data Entry

The RUN button initiates a subject test. The breath test operator selects the test type and enters the requested information. If the test type is TEST, the subject name field will be prepopulated with Test, Test. This test type is typically used for training or troubleshooting.

TEST TYPES:

1. DUI
2. Minor consuming
3. Other
4. TEST

SUBJECT'S NAME: Enter the full name of the subject being tested.

O.L.#: Enter the driver's license number of the subject.

OPERATOR NAME: Enter the operator name.

OPERATOR NUMBER: Enter the operator or supervisor number.

DEPT/AGENCY: Enter the agency name.

CASE/REPORT: Enter the agency case number.

The subject test sequence is pre-programmed and automatic. Once in progress, the user cannot alter the outcome of the test. It is the breath test operator or supervisor's responsibility to instruct the subject how and when to provide a sufficient breath sample.

The operator will provide a new mouthpiece for each subject test sequence. The operator may have a subject verify the condition of a new mouthpiece by having the subject blow through the opened mouthpiece before attaching it to the breath hose of the DataMaster; however, this is not a required step for a valid breath test.

The following are descriptions of each portion of the subject test sequence:

Alaska Scientific Crime Detection Laboratory

Alaska Breath Test Operator and Supervisor Manual

Effective: 9/6/2024

Version: 5.0

Diagnostic Check

Voltages and temperatures of the instrument are verified to fall within expected ranges. A passing Diagnostic test reads PASSED on the subject test strip.

Purging and Ambient Testing

Room air is drawn through the breath tube by the DC pump. The air passes through the sample chamber to clear it of any ethanol or other chemical vapor. During purging, the instrument measures the detector voltage twice to determine if they agree within a prescribed tolerance. If the measurements don't agree, the test aborts with an AMBIENT FAIL status message.

Ambient Zeroing

The instrument sets zero references for each of the three filters with only ambient air in the sample chamber.

Blank Test

A measurement of room air is taken after AMBIENT ZEROING. This ensures the sample chamber is clear before the subject sample is introduced. The expected result is 0.000.

Internal Standard Check

The quartz plate is inserted into the IR path to ensure that the accuracy has not changed since the last adjustment. A passing test reads VERIFIED.

External Standard

Ethanol dry gas is released through the gas line into the sample chamber, the sample is analyzed, and the results are displayed.

Purging (description same as above)

Ambient Zeroing (description same as above)

Blank Test (description same as above)

Please Blow (Subject Sample)

The subject provides a sample of their breath through the breath hose using a new mouthpiece. Intermittent beeping is produced until a sufficient breath flow rate is provided, followed by a sustained tone thereafter. If the subject flow rate drops below the minimum, intermittent beeping will resume.

The subject has two minutes (120 seconds) to provide an adequate breath sample with sufficient flow rate and volume. As the subject blows through the instrument, detector measurements are taken four times per second. When the [Sample Acceptance Parameters](#) have been met and the subject stops blowing, the final portion of exhaled breath is trapped in the sample chamber and analyzed to determine the reported alcohol concentration, if any.

Remaining Subject Test Steps

The measured ethanol result is determined but will be displayed as XXX until the subject test sequence has completed successfully.

(All remaining steps below are the same as those described above)

Purging

Ambient Zeroing

Alaska Scientific Crime Detection Laboratory

Alaska Breath Test Operator and Supervisor Manual

Effective: 9/6/2024

Version: 5.0

Blank Test
External Standard
Purging
Ambient Zeroing
Blank Test

Signature

If the signature option is On, the operator may add their electronic signature. After hitting Accept, test results are stored into memory and the subject test results print automatically. Tests may be accessed using the [Reports \(F2\)](#) menu.

Test Saved and Printed

After the test strip prints, the operator should verify the test completed and did not produce any status messages by examining the test strip. If a test strip fails to print or an error occurs during printing, the hit COPY button to print the last test in memory.

Subject Test Records

The official copy of the subject test record is the printed copy produced by the DataMaster DMT and stored with the law enforcement agency. The Crime Lab retrieves electronic data files from the instrument periodically via the attached modem line and maintains a database of tests retrieved from instruments in the field.

If the Crime Lab does not have an electronic copy of a test, this indicates that the data file for this test is not in the Crime Lab database. This may be more likely if the DataMaster DMT at an agency is not communicating with the lab.

Subject Test Printout and Graph

The DataMaster DMT features a graphical display with both the subject's breath flow rate and breath alcohol concentration. This graph is included in the test strip printout (see Image 8).

The x-axis of the graph (bottom) is the time (seconds) during the subject blow portion of the test. The y-axis (right-hand side) is the breath flow rate in liters per minute (L/M). The dotted line represents speed and duration of the subject's blow. The solid black line indicates the subject's alcohol level (measured zero in Image 8). The minimum flow rate is a horizontal line on the graph at 3 L/M.

NOTE: The y-axis does NOT include alcohol units that correspond with the black line and the alcohol level cannot be read from the graph. If the subject test has completed, the result of the test will be printed on the left-hand side of the subject test print out next to "Subject Sample" in units of g/210 L.

Alaska Scientific Crime Detection Laboratory

Alaska Breath Test Operator and Supervisor Manual

Effective: 9/6/2024

Version: 5.0

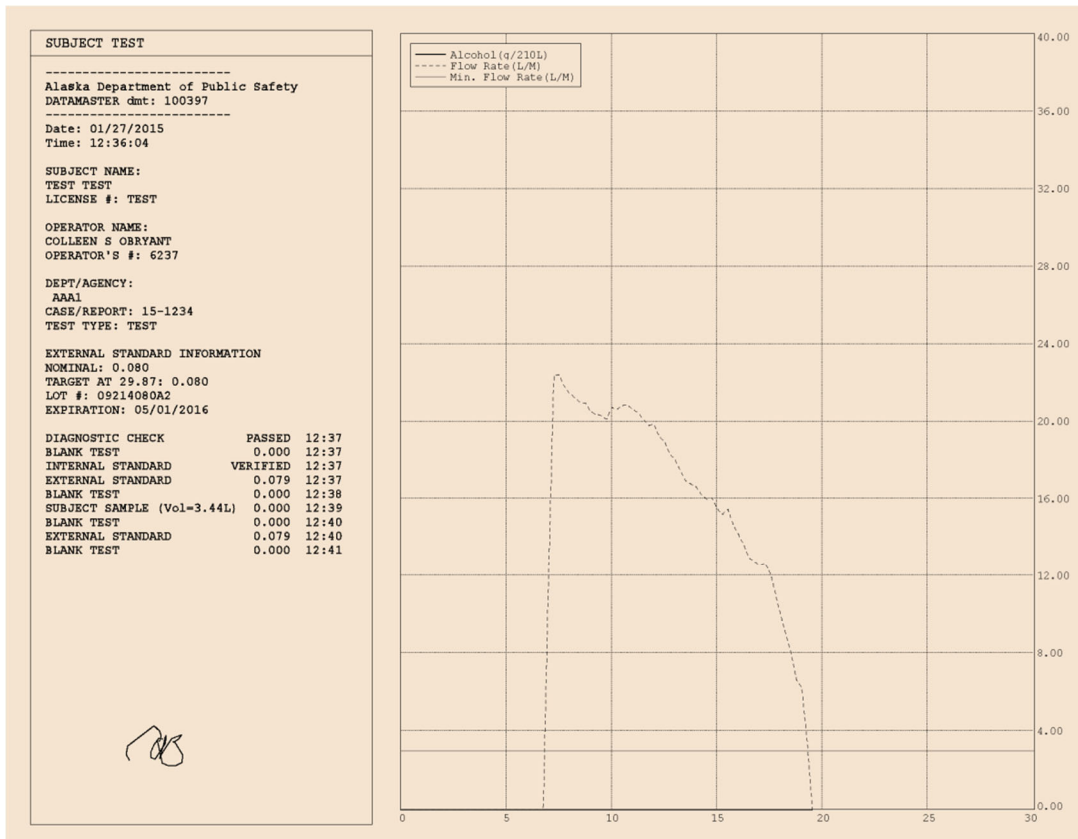

Image 8: A completed subject test printout.

Sample Acceptance Parameters

The DataMaster DMT accepts a breath sample for final measurement once the subject has provided a sample into the breath hose which met the necessary criteria for analysis:

- A minimum flow rate of 3 L/min.
- A minimum volume of 1.5 L.
- Ten or fewer attempts where the breath flow exceeds and then drops below the minimum flow rate (a start-stop).
- The breath alcohol profile must have reached a plateau (determined mathematically).
- Negative slope parameters must be met.
- The flow rate must fall below the minimum for the sample to be accepted (attempt has ended).

Alaska Scientific Crime Detection Laboratory

Alaska Breath Test Operator and Supervisor Manual
Effective: 9/6/2024 Version: 5.0

Non-Completed Tests

If a status message occurs, the subject test sequence will stop at the point at which the condition was detected. A dialog box will appear describing the status message and prompting the operator to resolve the condition and/or restart the test. If the status message occurs after the subject has blown, the subject's breath alcohol result will be printed as "XXX". See Image 9.

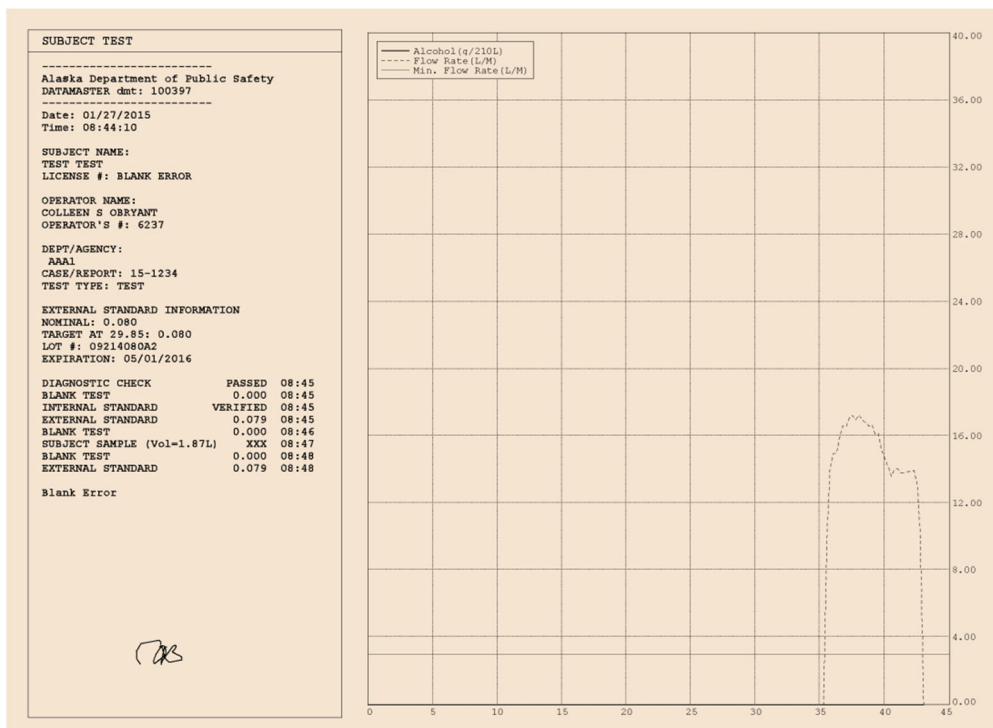

Image 9: A subject test showing a status message and XXX for the subject tests result.

External Standards

The dry gas external standard delivers a known quantity of ethanol both before and after the subject sample to ensure the DataMaster DMT is accurately recognizing and measuring ethanol concentrations.

Current external standards in use with the DataMaster DMT are commercially prepared cylinders from an ISO 17025-accredited manufacturer. Each cylinder has a label identifying the manufacturer lot number and expiration date.

External Standard is Exhausted

When the external standard pressure reaches 150 psi, the color of the tank pressure box on the home screen will change to red. At 100 psi, the instrument will no longer allow subject tests or VOCs to be performed until the standard cylinder is changed.

Replacing the External Standard

To exchange a cylinder, open the door on the cylinder compartment and twist the existing cylinder counterclockwise until the tank is free of the regulator. The breath test operator should then press the TANK CHANGE button on the home screen.

Alaska Scientific Crime Detection Laboratory

Alaska Breath Test Operator and Supervisor Manual
Effective: 9/6/2024 Version: 5.0

The screenshot shows a software window with two main sections. The top section, titled 'Supervisor Information', contains two rows of input fields. The first row has 'Name(F/M/L)' with the text 'JOHN', a small square icon with the letter 'Q', and 'TEST'. The second row has 'Certificate #' with the text '12345TEST'. The bottom section, titled 'Control Information', contains two rows of input fields. The first row has 'Lot #' with the text '1234QWERTY'. The second row has 'Expiration Date' with the text '12/12/2012'. At the bottom of the window are two buttons: 'Cancel' on the left and 'OK' on the right.

Image 10: DataMaster DMT Tank Change Screen

This will bring up a window prompting the breath test operator to enter his/her name and operator number and the lot number and expiration date of the external standard cylinder (Image 10). This information should be read directly from the new cylinder prior to inserting it into the dry gas compartment. **The breath test operator will then be asked to verify the lot number and expiration date entry by reentering the information.** If the entries do not match, the breath test operator will be asked to reenter the information from the beginning. After the information is entered correctly twice, the breath test operator will be prompted to ensure the cylinder is correctly installed in the dry gas compartment. The instrument will then initiate a VOC. The breath test operator will not be able to begin a subject test until this has been successfully completed.

External Standard Traceability

The lot number and expiration date entered by the breath test operator or supervisor will be the lot number and expiration date printed on the subject test performed using this external standard cylinder. It is important that the breath test operator ensures the lot number and expiration date are entered correctly. If the lot number and expiration date have been entered incorrectly, another tank change is required to update this information.

The DataMaster DMT will also display the external standard lot number and expiration date on the home screen. The box housing this information will change color to red when the external standard is 30 days from its expiration date. The DataMaster will not allow a subject test or VOC to be performed with an expired cylinder.

Receiving New External Standards

Replacement external standard cylinders need to be requested from the Crime Lab. Breath test supervisors are responsible for making these requests. Breath test operators should notify the breath test supervisors if their agency needs replacement cylinders.

Alaska Scientific Crime Detection Laboratory

Alaska Breath Test Operator and Supervisor Manual

Effective: 9/6/2024

Version: 5.0

Quality Assurance

Numerous measures are taken to ensure the quality of each subject test sequence. Diagnostic checks, external standards, internal standards, and blank tests are performed with each subject test sequence. A verification of calibration (VOC) is performed at least every 60 days and when the external standard is changed.

Types and Functions of Quality Assurance Measures

Every component of the test sequence (subjects tests and VOCs) must complete successfully for the overall test to be accepted. If a status message is generated at any point during a test sequence, the test will stop immediately and a status message will be displayed on the DataMaster DMT touch screen.

Diagnostic Check

A Diagnostic check is performed at the beginning of each subject test sequence and VOC. The diagnostic check is a self-test of the instrument including voltages, temperatures, and some internal components (e.g., pump).

Blank Test

A Blank test follows each purging cycle to verify the sample chamber is free of absorbing chemical vapor prior to taking a measurement.

Internal Standard

The Internal Standard is a quartz plate that is inserted into the IR path to demonstrate the accuracy of the instrument has not changed since the last adjustment. Each instrument stores the IR absorption value of this quartz standard in memory from the time of the last adjustment.

Each subsequent measurement of the quartz plate (Diagnostic, subject test, VOC) is compared to this stored value and must agree within a prescribed tolerance.

External Standard

The External Standard is a metal compressed gas cylinder containing a mixture of ethanol and nitrogen. The external standard cylinder is connected to the instrument through an internal regulator. External standards deliver a known quantity of ethanol to the instrument at specific times during the breath test procedure and VOC. This is done to test the ability of the instrument to accurately recognize and quantitate ethanol.

The allowable range for the external standard is +/- 0.005 from the target value adjusted for barometric pressure.

Verification of Calibration (VOC)

VOCs are a type of periodic check of the accuracy and precision of the DataMaster DMT. Instruments approved for evidential use must have a VOC performed at least every 60 days per 13 AAC 63.100. VOCs are also required after each change of the external standard tank.

A VOC consists of a Diagnostic test, internal standard check, and five tests of the external standard (each separated by blank tests). The DataMaster DMT software is programmed to automatically initiate VOC tests on the following dates at 12:00 PM (noon):

Alaska Scientific Crime Detection Laboratory

Alaska Breath Test Operator and Supervisor Manual

Effective: 9/6/2024

Version: 5.0

January 3rd
February 21st
April 11th
May 30th

July 18th
September 5th
October 24th
December 12th

If the instrument is being used (e.g., breath test being conducted) when the VOC would be initiated, the test will NOT be interrupted to perform the VOC. Furthermore, a VOC will not automatically initiate if a status message is on the instrument screen at that time.

The dates listed above are not the only acceptable date on which VOCs may be performed. VOCs may also be initiated by Breath Test Operators, Supervisors, or crime lab staff (including remotely) on dates other than those listed above.

Passing VOC reports are technically reviewed by crime lab staff, signed by the Scientific Director, and notarized before being posted on the crime lab website. A signed and notarized VOC indicates that that DataMaster DMT is approved for evidential use for the 60 days following the date on which the passing VOC was performed.

Records of VOCs are kept in the normal course of business at the crime lab.

Alaska Scientific Crime Detection Laboratory

Alaska Breath Test Operator and Supervisor Manual

Effective: 9/6/2024

Version: 5.0

Breath Test Supervisor Duties

Overview

Breath test supervisors are responsible for performing the following duties at their agencies:

- Timely notification and response to the crime lab regarding instrument issues, operator status, or questions about paperwork.
- Setting up, performing routine maintenance, and troubleshooting the instrument(s) currently assigned to their agency.
- Ensuring the instrument is connected to a dedicated modem line when the instrument is in service.
- Complete and submit paperwork associated with the instrument. Email is the preferred method: dps.scdl.toxicology@alaska.gov
- Timely filing of the Notice of Course Completion Form when requesting to train Breath Test Operators.
- Instructing fellow officers on operating the evidential breath testing instrument and properly administering a breath test using the approved training materials.
- Maintaining paperwork associated with breath test operators he/she has instructed. This includes informing the crime lab when breath test operators relocate or change names.
- Ordering external standards and other breath testing supplies:
 - DataMaster mouthpieces and forensic blood collection kits may be ordered directly through DPS Supply at: dps.supply.orders@alaska.gov
 - Supplies from the crime lab (e.g., external standards) may be ordered at: dps.scdl.toxicology@alaska.gov.
- Breath test supervisors may be asked to perform other duties or take on additional responsibilities depending on individual circumstances.

Breath Test Equipment Transportation

Shipments to Agencies

Breath testing equipment is shipped to agencies from the crime lab. The crime lab pays for outgoing shipping on instruments, supplies, associated equipment, and external standards. When instruments are shipped commercially, they will be placed in an approved shipping case. Instruments dropped off by crime lab staff or picked up by agency staff will generally not have a shipping case.

Shipments to the Crime Lab

Individual agencies are responsible arranging and paying for return shipment of instruments, instrument cases, and associated equipment to the crime lab. Agencies may use the most cost-effective means to ship the equipment. The breath test supervisor must notify the crime lab items are shipped back to the lab. The required information is the carrier name, waybill number, and date shipped.

When an agency receives a replacement instrument, the agency is responsible for packaging the old instrument package appropriately for shipment (e.g., inside the received case). If the agency does not have an instrument to return, the agency is responsible for shipping the empty case back to the crime lab.

Alaska Scientific Crime Detection Laboratory

Alaska Breath Test Operator and Supervisor Manual

Effective: 9/6/2024

Version: 5.0

Disposal of External Standards

Do NOT return empty or expired external standard cylinders to the crime lab. These items are considered hazardous materials and the shipper may be fined for shipping without proper training, packaging, and labeling.

Cylinders are not designed for reuse and must be rendered incapable of holding pressure before disposal.

DataMaster DMT Setup

Initial Setup

The following instructions are general guidelines for setting up an evidential breath test instrument.

1. Let the instrument sit Off for several hours or overnight so it warms to room temperature.
2. Make sure that an APC/line conditioner is present and installed according to the instructions with the unit.
 - a. APCs/line conditioners are supplied by the crime lab.
3. Attach the breath hose that came with the DataMaster as well as the analog modem line.
 - a. The breath hose may NOT be replaced in the field because the radio frequency sensitivity of that specific hose is set with the instrument at the lab.
4. Plug the instrument into the prepared APC/line conditioner and turn it On.
 - a. DataMaster DMTs have a defined startup and warmup period that cannot be bypassed.
5. Connect the external printer, ensure it is turned On, and contains paper.
6. When the printer diver dialog box appears, press the “X” at the top of the dialog box to close it - DO NOT PRESS “OKAY”.
 - a. If “OKAY” is pressed, unplug the printer USB cable and plug back in. Hit the “X” at the top.
7. Verify the date and time in the top right hand corner of the touch screen display. If the date and/or time are incorrect, correct them using the Functions menu under the DMT icon.
8. After the warmup period is completed, press the TANK CHANGE button and follow the instrument prompts for installing the external standard cylinder.
9. After the instrument has completed the VOC, fill out a Change in Instrument Status Form (found on the [Breath Alcohol Program webpage](#))
 - a. Email the completed form to dps.scdl.toxicology@alaska.gov to notify the lab that the instrument is in service.

Select Settings

The breath test supervisor has permission to change some settings on the DataMaster according to the individual agency’s preferences. Examples of settings that may be changed include: the number of copies of the test strip printed automatically, whether the alcohol value is displayed during the subject blow, the use of the Refusal query, and whether the graphical displays are On or Off. A detailed description of these options is listed under [Setup \(F3\)](#).

Default settings may be restored by selecting “Reset Options” from the Function menu under the DMT icon.

Instrument Date and Time

It is the responsibility of breath test operators and supervisors to ensure the correct date and time of any DataMaster they are using for evidential testing. Date and time settings are NOT monitored by the crime lab once an instrument has been placed in service.

Alaska Scientific Crime Detection Laboratory

Alaska Breath Test Operator and Supervisor Manual

Effective: 9/6/2024

Version: 5.0

Instrument Location

The following elements are required for the location of a DataMaster DMT:

1. Secure (limited access) to avoid loss, theft, or damage
2. Quality power source (use a crime lab-provided APC/line conditioner)
 - Failure to use a line conditioner may damage the instrument
 - For replacements or batteries, contact dps.scdl.toxicology@alaska.gov
3. Dedicated analog modem line for communication with the lab
 - Same as a fax machine uses
 - CANNOT be Voice-over-IP (VoIP)
4. Reasonable ventilation
 - Away from exhaust vents and direct heating/cooling units
 - Rear of the instrument is free from obstructions
 - In a location where a subject may stand away from the instrument before needing to blow
5. Away from sources of persistent radio frequency (RF) such as radio base stations

Agencies are required to provide a dedicated modem line for use with the DataMaster. Subject test data is uploaded to a host computer located in the crime lab. The uploading process is initiated by the crime lab. The crime lab can also remotely access the instruments for troubleshooting purposes.

Operator Training

Training Overview

Alaska Administrative Code (13 AAC 63.060) requires that all breath test operators complete a training course approved by the Scientific Director. Breath test supervisors provide instruction to most Operators; however, crime lab staff may provide operator training as well. The curriculum of the breath test operator course must include alcohol physiology, toxicology, pharmacology, DataMaster DMT instrument maintenance, practical operation, and administrative procedures. Students must complete an exam with a 75 percent or greater to pass the class and be certified as an operator. Certification and recertification of breath test operators require the same class, exam, and have the same exam score requirement.

Operator Training Materials

The breath program provides the approved breath test operator training materials (slide deck and activities) to the breath test supervisors. Only the approved training materials from the crime lab may be used; however, agencies are encouraged to discuss specific policies/procedures and perform hands-on training. The current operator training materials are available on the crime lab website breath alcohol program page: [https://dps.alaska.gov/Statewide/CrimeLab/DataMaster-\(1\)/datamaster](https://dps.alaska.gov/Statewide/CrimeLab/DataMaster-(1)/datamaster)

Operator Course Creation

At least 2 business days prior to instruction, the breath test supervisor will notify the crime lab about the course occurrence via the Breath Test Operator Certification/Recertification form (Notice of Course Occurrence) and submit it to dps.scdl.toxicology@alaska.gov. The crime lab will create the class in Acadis and assign the online exam to each student via their ACADIS Portal account. The lab will also verify Portal account access for each student. If a student does not have a Portal account, lab staff may create one (refer to [Breath Alcohol Program Acadis Working Instructions](#)).

Alaska Scientific Crime Detection Laboratory

Alaska Breath Test Operator and Supervisor Manual

Effective: 9/6/2024

Version: 5.0

Operator Course Completion

When a student passes the Breath Test Operator class and completes the exam, the crime lab will finalize the class and graduate successful students. Breath Test Operators will be issued an electronic operator certificate including a unique operator number. Certificates are issued from the scientific director and expire at 11:59 p.m. on December 31 of the third year after the year issued.

Each passing student's most current certificate is available in the student's ACADIS Portal account. Please contact the crime lab at dps.scdl.toxicology@alaska.gov if records before the current 3 year cycle are needed.

Supervisor Paperwork

Overview

Breath Test Supervisors act as the local point of contact for maintaining the DataMaster(s) at their agency. As such, they are expected to notify the laboratory of changes to the instrument such as relocation, troubleshooting, or taking an instrument in or out of service with the corresponding reason for doing so. The laboratory provides forms to document this information.

Change in Instrument Status Form

The breath alcohol program keeps a record of all maintenance and movement of the DataMaster instruments. Breath test supervisors should notify the crime lab of any change in status of the instrument(s) at their agency by filling out a Change in Instrument Status Form and submitting it to the crime lab. In some instances, lab staff may also fill out Change in Instrument Status Forms on behalf of an agency.

The following are examples of situations that would require a Change in Instrument Status Form to be filled out:

1. Placing an instrument in service or removing an instrument from service.
2. Relocation of an instrument to a new building.
3. Documenting instrument issues/maintenance.

This form is available on the breath alcohol program website:

[https://dps.alaska.gov/Statewide/CrimeLab/DataMaster-\(1\)/datamaster](https://dps.alaska.gov/Statewide/CrimeLab/DataMaster-(1)/datamaster).

The completed Change in Instrument Status Form should be provided to the crime lab (email preferred: dps.scdl.toxicology@alaska.gov) after which they will be entered into the instrument file.

Change in Operator Status Form

Prior to the use of the Acadis system (beginning in March 2022), the breath alcohol program maintained a database of breath test operator information to track operator names, numbers, assigned agency, and operator certification date(s). This system is still in use for all breath test supervisors and any breath test operators that have not trained under the Acadis system. To keep this legacy database as accurate as possible, breath test supervisors are asked to submit a Change in Operator Status form whenever a breath test operator's status changes with regards to the breath alcohol program. This form is not required by the program and e-mail notification is also acceptable (dps.scdl.toxicology@alaska.gov).

Situations that would justify a Change in Operator Status form include:

1. New breath test operator is hired at an agency

Alaska Scientific Crime Detection Laboratory

Alaska Breath Test Operator and Supervisor Manual

Effective: 9/6/2024

Version: 5.0

2. Breath test operator's employment ends for any reason
3. Breath test operator transfers to a different agency or location
4. Name change such as after marriage

This form is available on the breath alcohol program website:

[https://dps.alaska.gov/Statewide/CrimeLab/DataMaster-\(1\)/datamaster](https://dps.alaska.gov/Statewide/CrimeLab/DataMaster-(1)/datamaster).

Change in Operator Status forms are not retained by the lab once the corresponding information is recorded in the database. For updates to operator information in the Acadis system, this must be completed by contacting the Alaska Police Standards Council (apsc@alaska.gov) and is not generally done by lab staff.

Ordering Breath Alcohol Testing Supplies

Overview and Agency Responsibilities

Breath alcohol testing requires a variety of approved equipment and supplies to maintain the DataMaster and successfully conduct evidential breath tests. It is the responsibility of the agency to request supplies in a sufficient amount of time to maintain the operation of their instrument.

Types and Sources of Supplies

Alcohol testing supplies fall into 3 general categories:

1. Supplies provided by DPS Supply (email dps.supply.orders@alaska.gov):
 - a. DataMaster DMT mouthpieces
 - b. Forensic blood collection kits
2. Supplies provided by the lab (email dps.scdl.toxicology@alaska.gov):
 - a. Dry gas external standard tanks (see **NOTE**)
 - b. Replacement APC batteries or line conditioners
3. Consumables that must be replaced by the agency:
 - a. Printer cartridges
 - b. Printer paper
 - c. Replacement printer (after the first one provided by the lab)
 - i. Contact the lab for compatibility information

NOTE: Depending on location, it may take 2 to 3 weeks to receive a replacement external standard tank. Please notify the lab in advance to allow time for shipping.

Alaska Scientific Crime Detection Laboratory

Alaska Breath Test Operator and Supervisor Manual

Effective: 9/6/2024

Version: 5.0

Status Messages and Troubleshooting

Overview

The DataMaster DMT is designed to monitor itself (e.g., sample chamber temperature) as well as the external environment (blank test, radio frequency antenna) to ensure that it is operating within manufacturer and breath alcohol program requirements. If the instrument detects a condition outside of established parameters, any active test will be aborted, and a status message will be displayed.

This section describes possible causes of common status messages and possible methods of resolution. Status messages are part of the normal operation of the instrument; however, repeated or frequent status messages may indicate a performance issue requiring attention from the lab.

If a status message is NOT triggered, this means that the instrument did not detect the corresponding condition during the test sequence.

When a Status Message Occurs

When a status message occurs, the recommended sequence of events is as follows. **NOTE:** This only discusses actions related to the DataMaster and is not a comprehensive guide for DUI processing.

1. The breath test operator should read the on-screen message and follow the instructions.
 - a. Examples:
 - i. For Maximum Attempts Exceeded, instruct the subject to provide one long, steady breath. Test the subject a second time.
 - ii. For Blank Error, move the subject away from the DataMaster except when ready to blow. Test the subject a second time.
2. The operator may refer to the [Troubleshooting Suggestions](#) section of this manual for more information on resolving the status message.
3. If the operator is unable to resolve the situation, contact the breath test supervisor.
4. The breath test supervisor may use their advanced training to troubleshoot the issue.
 - a. The breath test supervisor must complete a Change in Instrument Status Form even if the issue is resolved ([https://dps.alaska.gov/Statewide/CrimeLab/DataMaster-\(1\)/datamaster](https://dps.alaska.gov/Statewide/CrimeLab/DataMaster-(1)/datamaster)).
5. If the breath test supervisor is unable to resolve the situation, they may contact the crime lab (dps.supply.orders@alaska.gov).

Status Message Descriptions

Ambient Fail

This message is caused by the environment around the DataMaster, usually poor air quality (e.g., chemical vapor, room too hot, vehicle exhaust nearby).

Maximum Attempts Exceeded

The subject provided 10 incomplete attempts during the allotted two-minute window. An attempt is registered when the subject's breath flow first exceeds then drops below the minimum flow rate (3 liters per minute).

Incomplete

The subject did not provide a sample that met the [Sample Acceptance Parameters](#) within the two minutes allotted.

Alaska Scientific Crime Detection Laboratory

Alaska Breath Test Operator and Supervisor Manual

Effective: 9/6/2024

Version: 5.0

Invalid

A negative slope was detected in the subject breath alcohol concentration which exceeded the manufacturer tolerance.

Interference (Subject Sample)

A substance other than (or in combination with) ethanol was detected in the subject's breath sample.

Interference (External Standard)

One or both of the filter 2 and/or filter 3 readings were outside of the manufacturer's tolerance during an external standard test.

Subject Sample Displays XXX

A status message occurred after the subject blew into the DataMaster. This is considered an incomplete test and any subject alcohol value from this test sequence will not be supported by the Breath Alcohol Program.

RFI Detected

The radio frequency detector in the breath hose detected radio interference near the instrument. This commonly occurs when a portable radio transmits close to the instrument.

Standard Out of Range

The dry gas external standard reading was outside of the allowable tolerance. The allowed tolerance is +/- 0.005 from the external standard target value adjusted for barometric pressure.

Alaska Scientific Crime Detection Laboratory

Alaska Breath Test Operator and Supervisor Manual

Effective: 9/6/2024

Version: 5.0

Troubleshooting Suggestions

The table below lists common status messages and suggestions on how to address them. The breath test supervisor will determine when contacting the crime lab is warranted. The supervisor may contact the lab at any point during troubleshooting.

Status Message	How to Address
Ambient Fail	<ol style="list-style-type: none">1. Move the subject away from the DataMaster2. Attempt the test again3. If the message occurs again, ventilate the room (e.g., open door)4. Purge the sample chamber (under DMT icon, Functions)5. Perform a non-drinking subject test6. If the message persists, contact breath test supervisor.
Blank Error	<ol style="list-style-type: none">1. Move the subject away from the DataMaster2. Attempt the test again3. If the message occurs again, ventilate the room (e.g., open door)4. Purge the sample chamber (under DMT icon, Functions)5. Perform a non-drinking subject test6. If the message persists, contact breath test supervisor.
Diagnostic Check Failed (Breath Tube Temperature Too Low)	<ol style="list-style-type: none">1. Ensure the breath tube heater connection is firmly inserted.2. Wait a couple minutes then attempt the test again.3. If the message persists, contact the breath test supervisor.
Detector Overflow	<ol style="list-style-type: none">1. If the status message occurs during a<ol style="list-style-type: none">a. Subject test - Attempt a second testb. VOC – Contact the breath test supervisor.2. If the message persists, contact the breath test supervisor.
Fatal System Error	<ol style="list-style-type: none">1. Wait until the DataMaster completely reboots or move to another instrument.2. Attempt the subject test again.3. Contact the breath test supervisor even if the message does not occur again.
Filter Wheel Error	<ol style="list-style-type: none">1. Attempt the test again. If the message occurs again, contact the breath test supervisor.2. Run a filter test (under DMT Icon, Functions) and see if the filter will realign itself.3. Reboot the instrument.4. If the message persists, contact the breath test supervisor.
Filter 1, 2 or 3 Won't Zero	<ol style="list-style-type: none">1. Reboot instrument.2. If the message persists, contact the breath test supervisor.
Gas Flow Error	<ol style="list-style-type: none">1. Attempt the subject test again.2. Contact breath test supervisor to check for kinked tubing and to ensure check valve is upright.3. If the message persists, contact the crime lab.

Alaska Scientific Crime Detection Laboratory

Alaska Breath Test Operator and Supervisor Manual

Effective: 9/6/2024

Version: 5.0

Problem	How to Address
Incomplete	<ol style="list-style-type: none"> 1. Instruct the subject to provide one long, steady breath. 2. Attempt the test one more time using a new DataMaster mouthpiece. Have the subject demonstrate blowing through the mouthpiece before attaching it to the breath hose. 3. If subject is attempting to provide a sample and either the airflow is blocked or the flow is not registering, perform a non-drinking subject test. 4. If the flow is blocked or not registering, contact the breath test supervisor.
Subject sample blowing is too hard or too easy	<ol style="list-style-type: none"> 1. Perform a non-drinking subject test using a new DataMaster mouthpiece. 2. If the sample accepts properly, attempt the subject test again using a new mouthpiece. Have the subject demonstrate blowing through the mouthpiece before attaching it to the breath hose. 3. If the issue persists, contact the breath test supervisor.
Interference (Subject Sample)	<ol style="list-style-type: none"> 1. If the instrument was recently put into service, ensure it has had at least a few hours to warm up completely. 2. Instruct the subject to provide one long, steady breath. 3. Attempt the test one more time. 4. If INTERFERENCE DETECTED occurs twice in a row on the same subject, get a search warrant for blood. 5. If the INTERFERENCE DETECTED status message occurs frequently, contact the breath test supervisor.
Interference (External Standard)	<ol style="list-style-type: none"> 1. Attempt the subject test again. 2. If the message persists, contact the breath test supervisor to purge the gas line.
Internal Standard Error	<ol style="list-style-type: none"> 1. Reboot the instrument. 2. Attempt the subject test again. 3. If the message persists, contact the breath test supervisor.
Invalid Sample	<ol style="list-style-type: none"> 1. Instruct the subject to provide one long, steady breath. 2. Attempt the test one more time. Watch for inappropriate blowing behavior such as: blowing around the mouthpiece, blocking mouthpiece with tongue, etc. 3. If INVALID occurs twice in a row on the same subject, get a search warrant for blood. 4. If INVALID occurs frequently, contact the breath test supervisor.
Maximum Attempts Exceeded	<ol style="list-style-type: none"> 1. Instruct the subject to provide one long, steady breath. 2. Attempt the test one more time. Watch for the subject to start and stop instead of providing one steady breath. 3. If it is not possible to get a completed test, get a search warrant for blood.

Alaska Scientific Crime Detection Laboratory

Alaska Breath Test Operator and Supervisor Manual

Effective: 9/6/2024

Version: 5.0

Problem	How to Address
Pump Error	<ol style="list-style-type: none">1. Do not insert the mouthpiece before the subject is ready to blow and remove the mouthpiece immediately once the subject has finished blowing.2. Use a new mouthpiece and restart the test.3. If the message persists, switch to a different instrument or get a search warrant for blood. Contact the breath test supervisor.4. Remove breath hose from instrument and blow through it to check for blockage.5. If the message occurs repeatedly, contact the crime lab.
RFI Detected	<ol style="list-style-type: none">1. Ensure any portable radios are turned Off or are located away from the DataMaster.2. Attempt the subject test again.3. If the message persists, contact the breath test supervisor.
Sample Chamber Temperature Check	<ol style="list-style-type: none">1. Reboot the instrument.2. After the instrument has completed its restart cycle, attempt the subject test again.3. If the message persists, contact the breath test supervisor.
Standard Out of Range	<ol style="list-style-type: none">1. Move the subject away from the DataMaster and ventilate the room (e.g., open door).2. Attempt the test again.3. If the message occurs again, contact the breath test supervisor to consider replacing the dry gas external standard tank.4. If the message persists after a tank change, contact the crime lab.
External Standard Pressure Leak	<ol style="list-style-type: none">1. Unscrew and reinsert the dry gas external standard cylinder.2. If leaking continues, contact the breath test supervisor to have them replace the regulator o-ring.3. If the leak persists, contact the crime lab.
Suck Back Error	<ol style="list-style-type: none">1. Instruct the subject to provide one long, steady breath.2. Attempt the test one more time. Watch for inappropriate blowing behavior such as: blowing around the mouthpiece, blocking mouthpiece with tongue, etc.3. If Suck Back Error occurs twice with apparently proper blowing, contact the breath test supervisor and get a search warrant for blood.4. If message persists despite proper blowing, contact the crime lab.
Test Strip Won't Print	<ol style="list-style-type: none">1. Ensure the printer is On, has paper, and is not out of ink.2. Unplug the printer USB cable from the DataMaster then plug it back in. When the driver popup message appears, hit the "X".3. If the desired printout is the last test run, select COPY on the DataMaster home screen. If the desired printout is NOT the last test run, select the DMT icon, then Reports, then Subject Tests and scroll to the date and time of the desired subject test. Click on the subject test to load, then Print.4. If the test still does not print, contact breath test supervisor.

Alaska Scientific Crime Detection Laboratory

Alaska Breath Test Operator and Supervisor Manual

Effective: 9/6/2024

Version: 5.0

Problem	How to Address
Touch screen unresponsive, jumbled characters, or any status messages not described above.	<ol style="list-style-type: none">1. Reboot instrument.2. If the message persists, contact the breath test supervisor.3. If the supervisor is unable to resolve, contact the crime lab.
Repeated status messages of any kind	<ol style="list-style-type: none">1. Contact the breath test supervisor.

Alaska Scientific Crime Detection Laboratory

Alaska Breath Test Operator and Supervisor Manual

Effective: 9/6/2024

Version: 5.0

References

Ethanol Section References

1. International Center for Alcohol Policies, What is a “Standard Drink”?, *ICAP Reports 5* (September 1998)
2. P Harding, Interpretation of alcohol results, *Alcohol Toxicology for Prosecutors, American Prosecutors Research Institute* (2003) 5-28
3. AW Jones, Evidence-based survey of the elimination rates of ethanol from blood with applications in forensic casework, *Forensic Science International* 200 (2010) 1-20
4. Alaska Administrative Code 28.35.030
5. RF Borkenstein, RF Crowther, RP Shumate, WB Ziel, and R Zylman, The Role of the Drinking Driver in Traffic Accidents, *Department of Police Administration, Indiana University, Bloomington, Indiana* (1964)
6. RD Blomberg, RC Peck, H Moskowitz, M Burns, and D Fiorentino, Crash risk of alcohol involved driving: a case-control study, *Dunlap and Associates, Inc.* (2005)

DataMaster DMT References

7. ASB Standard 055, First Edition 2022 Standard for Breath Alcohol Measuring Instrument Calibration
8. Alaska Criminal and Traffic Law Manual
9. Garriott’s Medicolegal Aspects of Alcohol, Fifth Addition Edited By: Garriott J.; Contributing Authors Anderson W, Basteyns B, Caplan Y, Dubowski K, Goldberger B, Harding P, Head W, Jones A, Jones G, Landau J, et al. 2003. Medical-Legal Aspects of Alcohol. Fourth Edition, Tucson (AZ):Lawyers and Judges Publishing Company, Inc.
10. Product Overview DMT, National Patent Analytical Systems, Inc., 2010

Alaska Scientific Crime Detection Laboratory

Alaska Breath Test Operator and Supervisor Manual

Effective: 9/6/2024

Version: 5.0

Status and Test Codes

Status Code	Status Message
0	Communication Error
1	Communication Error
2	Communication Error
3	Communication Error
4	Communication Error
5	User Abort
6	Pump Error
7	Filter 1 Won't Zero
8	Filter 2 Won't Zero
9	Filter 3 Won't Zero
10	Ambient Fail
11	Standard Out of Range
12	Simulator Time Out
13	Simulator Temp High
14	Simulator Temp Low
15	Simulator Temp Unknown
16	Blank Error
17	Internal Standard Error
18	Invalid Sample
19	Interference Detected (External Standard)
20	Detector Overflow

Status Code	Status Message
21	Sample Chamber Temp High
22	Sample Chamber Temp Low
23	RFI Detected
24	Barometer Error
25	Breath Tube Temp High
26	Breath Tube Temp Low
27	Incomplete Sample
28	Filter Wheel Error
29	Sample Agreement Error
30	Suck Back Error
31	Calibration Error
32	Undefined Error
33	Diagnostic Failed
34	Fuel Cell Disagreement
35	Fuel Cell Error
36	Tank Pressure Too Low
37	Gas Flow Error
40	Static Analysis Error
100	Standard Deviation Error
101	Maximum Attempts Exceeded
102	Interference Detected (Subject Sample)

TEST CODES

I	Incomplete
V	Invalid
X	Interference Detected
R	Subject Refused

*Please note this is a list provided by the manufacturer. Not all codes may be applicable to Alaska instruments.

Alaska Scientific Crime Detection Laboratory

Alaska Breath Test Operator and Supervisor Manual

Effective: 9/6/2024

Version: 5.0

Revision History

Location	Revision made
Throughout	Created table of contents, updated headers, formatting, spelling and grammar as needed.
Staff Roles and Contact Methods	Updated information to reflect current breath program staffing
Abbreviations and Definitions	Temporarily removed definition of “Masking” until 3.03 software is ready to go live
Result Masking	Temporarily removed section until 3.03 software is ready to go live
Troubleshooting Suggestions – Incomplete, Subject sample blowing is too hard or too easy	Added detail about using new mouthpieces with each test sequence and potential step of verifying mouthpiece condition by having the subject blow through it before connecting to the DataMaster