

Alaska Scientific Crime Detection Laboratory

Alaska Breath Test Operator and Supervisor Manual

Issued: 05/12/2016

Version: ABTOSM 2016 R0

Effective: 05/16/2016

Status: Active

SECTION 1	Breath Alcohol Program Contact Information
SECTION 2	Introduction
SECTION 3	Ethanol
SECTION 4	Evidential Breath Test Instruments
SECTION 5	Subject Tests
SECTION 6	Quality Assurance
SECTION 7	Breath Test Supervisor Duties
SECTION 8	References
SECTION 9	Status Codes
SECTION 10	Revision History

Alaska Scientific Crime Detection Laboratory

Alaska Breath Test Operator and Supervisor Manual

Issued: 05/12/2016
Effective: 05/16/2016

Version: ABTOSM 2016 R0
Status: Active

SECTION 1

BREATH ALCOHOL PROGRAM CONTACT INFORMATION

Breath Alcohol Program
Alaska Scientific Crime Detection Laboratory
4805 Dr. Martin Luther King Junior Avenue
Anchorage, Alaska 99507
(907) 269-5740

Charles Foster, Scientific Director
Charles.Foster@Alaska.gov
(907) 269-5760

Brandi Barnett, Forensic Scientist III
(907) 269-5695

Colleen O'Bryant, Forensic Scientist III
(907) 269-5783

Nikki Roth, Forensic Technician
(907) 269-5592

Program E-mail
dps.scdl.toxicology@alaska.gov

Alaska Scientific Crime Detection Laboratory

Alaska Breath Test Operator and Supervisor Manual

Issued: 05/12/2016

Version: ABTOSM 2016 R0

Effective: 05/16/2016

Status: Active

SECTION 2

INTRODUCTION

This manual is intended to be a training guide for Alaska breath test operators and supervisors of the approved evidential breath test instruments. It is not a comprehensive procedure manual for impaired driving and DUI processing. Officers should use this to supplement their agencies' policies and procedures. If there are additional questions officers should contact the breath alcohol program at the Alaska Scientific Crime Detection Laboratory (crime lab).

The breath alcohol program is part of the crime lab. It includes the scientific director of the breath and blood alcohol testing program, forensic scientists and forensic technicians. The duties of the breath alcohol program include: breath test instrument certification, calibration and maintenance; administration of records; training and court testimony. One responsibility of the breath alcohol program is to train the breath test supervisors. This is accomplished by providing certification and recertification courses at the crime lab. In turn the breath test supervisors are responsible for training the breath test operators in their area.

The following information is taken from the Alaska Criminal and Traffic Law Manual:

13 AAC 63.050. Breath test operator certification*

(a) To be certified as an operator of a breath test instrument, an applicant must successfully complete a course of instruction approved by the scientific director. The course must include at least four hours of instruction in the theory of alcohol physiology, toxicology, pharmacology, instrument maintenance, practical operation, and administrative procedures. The applicant must also obtain a score of 75 percent or higher on a written examination, approved by the scientific director, covering the content of the course.

(b) The scientific director shall, in his or her discretion, issue an operator certificate and operator identification number to an applicant upon receipt of written notice from a supervisor that the applicant has successfully completed a course of training and examination that meets the requirements of this section. An operator certificate expires at 11:59 p.m. on December 31 of the third year after the year issued.

13 AAC 63.060. Breath test operator recertification*

(a) To renew a breath test operator's certification, a breath test operator must, during the period of the operator's current certification,

(1) complete a refresher course approved by the scientific director that includes at least four hours of instruction and training; and

(2) obtain a score of 75 percent or higher on a written examination, approved by the scientific director, covering the content of the refresher course.

Alaska Scientific Crime Detection Laboratory

Alaska Breath Test Operator and Supervisor Manual

Issued: 05/12/2016

Version: ABTOSM 2016 R0

Effective: 05/16/2016

Status: Active

(b) The breath test supervisor shall submit a written notice to the scientific director that an operator seeking to renew a breath test operator's certificate has complied with the requirements of (a) of this section. Upon receipt of the notice, the scientific director shall renew the breath test operator certificate and operator identification number.

(c) A breath test operator certificate that has been renewed under this section expires at 11:59 p.m. on December 31 of the third year after the year issued.

13 AAC 63.070. Breath test supervisor certification and duties*

(a) To be certified as a breath test supervisor, an applicant must

(1) complete a 22-hour supervisor training course approved by the scientific director; the course must include instruction in the theory of alcohol physiology, pharmacology, toxicology, instrument function, instrument maintenance, practical operation, administrative procedures, legal considerations, and other pertinent subjects as required by the scientific director;

(2) possess a valid instructor's certificate issued by the Alaska Police Standards Council under 13 AAC 87.040; and

(3) obtain a score of 75 percent or higher on a written examination, approved by the scientific director, covering the content of the training course.

(b) The scientific director shall issue a breath test supervisor certificate and an identification number to an applicant if the applicant has met the requirements of (a) of this section. A breath test supervisor certificate expires at 11:59 p.m. on December 31 of the third year after the year issued.

(c) In addition to performing all the duties of an operator, a breath test supervisor may train breath test operators and perform routine maintenance on a breath test instrument. A supervisor certificate is also an operator's certificate.

(d) A breath test supervisor shall inform the scientific director of the location of breath test instruments and the status of breath test operators under the breath test supervisor's supervision.

13 AAC 63.080. Breath test supervisor recertification

(a) To renew a breath test supervisor's certification, a supervisor must, during the period of the supervisor's current certification,

(1) complete a refresher course approved by the scientific director that includes at least 15 hours of instruction and training; and

(2) obtain a score of 75 percent or higher on a written examination, approved by the scientific director, covering the content of the refresher course.

(b) If the breath test supervisor has met the requirements of (a) of this section, that supervisor may request in writing a renewed certificate from the scientific director. Upon receipt of the request, the scientific director shall renew the certificate.

(c) A breath test supervisor certificate that is renewed under this section expires at 11:59 p.m. on December 31 of the third year after the year issued.

* These codes were updated effective 12/28/2012.

Alaska Scientific Crime Detection Laboratory

Alaska Breath Test Operator and Supervisor Manual

Issued: 05/12/2016

Version: ABTOSM 2016 R0

Effective: 05/16/2016

Status: Active

BREATH TEST INSTRUMENT ASSIGNMENT TO AGENCIES

Evidential breath test instruments are the property of the State of Alaska. Exceptions exist where agencies have purchased instruments independently. The state-owned instruments are entrusted to the responsible care and use by the assigned agency. Breath test supervisors are responsible for the day-to-day operation and upkeep of these instruments and are accountable for problems arising from neglect and/or misuse of the instruments.

Evidential breath instruments are placed at law enforcement and other locations by the scientific director. The crime lab will supply and maintain breath test instruments at the designated location. The crime lab reserves the right to remove an instrument from a location.

Agencies are expected to:

- Properly maintain and operate the instrument.
- Have a dedicated functioning modem line.
- Communicate with the crime lab.
- Have a breath test supervisor at the breath test instrument location.

Alaska Scientific Crime Detection Laboratory

Alaska Breath Test Operator and Supervisor Manual

Issued: 05/12/2016

Version: ABTOSM 2016 R0

Effective: 05/16/2016

Status: Active

SECTION 3

ETHANOL

Ethanol

The chemical name for the alcohol that is commonly consumed is ethanol (or ethyl alcohol). In this document, alcohol and ethanol are used interchangeably. Ethanol is a small, water soluble molecule that is readily absorbed and distributed by the blood throughout all of the water-containing components of the body.

Alcohol Proof

The concentration of an alcoholic beverage is commonly listed in the units of proof. The concentration of alcohol in percent by volume is one half the proof.

80 Proof = 40 % (v/v)

The common abbreviations for alcohol percent by volume are abv and % (v/v). The volume of pure ethanol can be converted to its mass by using ethanol's density.

1 mL ethanol = 0.789 grams ethanol

Standard Drinks

The term "standard drink" applies to drinks of "standard" alcoholic strength. In the United States, a standard drink is officially defined as containing the equivalent of 14 grams of ethanol.¹ The resulting concentration of ethanol (% v/v) when 14 grams of pure ethanol is diluted to a given volume can be calculated as follows:

Concentration in abv = $(100 \times 14 \text{ g}) / (\text{volume of drink in oz} \times 29.6 \text{ mL/oz} \times 0.789 \text{ g/mL})$

This gives the following drink concentrations for a United States standard alcoholic drink containing 14 grams of alcohol:

12 ounces of 5% (v/v) beer

5 ounces of 12% (v/v) wine

1.5 ounces of 40% (v/v) spirits

Common unit conversions

The crime laboratory reports blood alcohol concentrations in units of "grams per 100 milliliters" abbreviated as g/100mL. Other laboratories may use the units of "grams per deciliter" abbreviated g/dL. Because one deciliter equals 100 milliliters, these units are equivalent.

0.080 g/100mL = 0.080 g/dL

Alaska Scientific Crime Detection Laboratory

Alaska Breath Test Operator and Supervisor Manual

Issued: 05/12/2016

Version: ABTOSM 2016 R0

Effective: 05/16/2016

Status: Active

Alcohol concentrations reported in medical results are commonly in units of “milligrams per deciliter” abbreviated mg/dL. Because one gram equals 1000 milligrams, mg/dL can be converted to g/dL by dividing by 1000.

$$80 \text{ mg/dL} = 0.080 \text{ g/dL} = 0.080 \text{ g/100mL}$$

Converting Serum and Plasma Results to Whole Blood

Although hospital results frequently report alcohol concentrations as being from blood, serum or plasma is often the sample analyzed. Serum is the liquid that remains when blood is collected without an anticoagulant and allowed to clot. Plasma is the liquid separated from whole blood and treated with an anticoagulant when the blood cells are removed.

Ethanol distributes throughout all of the water-containing components of the body. Since serum or plasma represents the water portion of whole blood, it will have a higher alcohol content than the whole blood from which it came. The average ratio of serum and plasma alcohol content to whole blood alcohol content is approximately 1.14:1 with a range of 1.04:1 to 1.26:1.² The whole blood concentration can be calculated from the serum or plasma alcohol concentration result by using the average ratio.

$$\text{Whole blood alcohol content} = \text{Serum or Plasma Alcohol Content} / 1.14$$

Breath and Blood Alcohol

Breath alcohol instruments indirectly estimate a person’s blood alcohol concentration using a calibration factor called the blood/breath ratio. This ratio describes how the concentration of alcohol in someone’s venous blood relates to the concentration of alcohol in their deep lung air. Breath instruments in the United States assume a blood/breath ratio of 2100:1. Studies have shown that the blood/breath ratio is less than 2000:1 during the absorptive phase, increasing to about 2100:1 by 90 minutes post - dosing, and further increasing to 2300:1 or 2400:1 later in the post-absorptive phase.³ Because of the variability in an individual’s blood/breath ratio, a breath alcohol concentration result should not be converted to a blood alcohol concentration. Despite this variability in the blood/breath ratio, both breath and blood alcohol testing are valid when determining someone’s current alcohol content. The Alaska Administrative Code lists the legal limit of 0.08 in both blood (g/100mL) and breath (g/210L) units making any conversion between the two unnecessary.⁴

Impairing Effects of Ethanol

Ethanol is a central nervous system depressant. The magnitude of its depressant effects is dependent on the dose consumed. The depressant effects of alcohol cause an increase in reaction time (decrease in information processing rate), a decrease in judgment, and a decrease in coordination.

Alaska Scientific Crime Detection Laboratory

Alaska Breath Test Operator and Supervisor Manual

Issued: 05/12/2016

Version: ABTOSM 2016 R0

Effective: 05/16/2016

Status: Active

Studies have compared the relative vehicle crash risk of people at a specific alcohol level to people with no alcohol in their system.^{5, 6} Relative crash risk asks the question, “What are the odds of a person getting in an accident at a particular BAC compared to the odds of a person getting in an accident with no alcohol in their system?” The largest of these studies used crash data from Grand Rapids, MI and more recently in Long Beach, CA and Fort Lauderdale, FL.

The authors of the Grand Rapids study concluded that at above a 0.08% blood alcohol level, factors other than alcohol became less and less significant and eventually seemed to disappear.⁵ This is compelling evidence that alcohol is a major factor in traffic crash causation. In addition to these studies, the Committee on Alcohol and Other Drugs of the National Safety Council have concluded that all individuals are impaired with respect to operating a motor vehicle at concentrations of 0.08 and above, while some individuals are impaired with respect to driving at concentrations below 0.08.²

General Alcohol Concentration Curve

When a person consumes alcohol, the time course of ethanol concentration in the blood can be divided into three phases: absorptive, peak, and post-absorptive.

As soon as alcohol is absorbed into the body, the body begins to eliminate it. During the absorptive phase, alcohol concentration is increasing at a faster rate than it is being eliminated, at the peak, absorption and elimination rates are equal, and after absorption of alcohol is complete, alcohol concentration will decrease until it is completely eliminated.

Absorption

When alcohol is ingested, about 20-25% of the dose is absorbed through the stomach lining and the remaining 75-80% is absorbed when it leaves the stomach and enters the small intestine.² The most important factor affecting the rate of absorption is the presence of food in the stomach concurrent with alcohol. Peak concentrations are generally attained within 30 to 60 minutes of the cessation of drinking.² When alcohol is consumed successively over time, as in a social drinking situation, peak concentrations are generally attained within 30 minutes of the last drink and may even be attained before the last drink is finished.²

Distribution

Because alcohol is completely water soluble, the alcohol concentration in the body after absorbing a given dose is proportional to a person's total water content. The more water a person has in their body, the less concentrated a given dose of alcohol will be after it is absorbed and distributed. About 68% of an average male's body weight is due to body water, while the percentage is 55% for average females.²

Alaska Scientific Crime Detection Laboratory

Alaska Breath Test Operator and Supervisor Manual

Issued: 05/12/2016

Version: ABTOSM 2016 R0

Effective: 05/16/2016

Status: Active

Elimination

The majority of the human population eliminates alcohol at a rate between 0.010 g/100mL/hr and 0.025 g/100mL/hr with an average elimination rate of 0.017 g/100mL/hr.³ Factors that may have an effect on an individual's elimination rate include how well-nourished the person is and whether continuous drinking has occurred over a period of several days.³ An individual's elimination rate will vary and, rather than speculating over what their specific elimination rate was during the time of interest, it is more practical to use the elimination range and average listed above.³

References

1. International Center for Alcohol Policies, What is a "Standard Drink"?, *ICAP Reports 5* (September 1998)
2. P Harding, Interpretation of alcohol results, *Alcohol Toxicology for Prosecutors, American Prosecutors Research Institute* (2003) 5-28
3. AW Jones, Evidence-based survey of the elimination rates of ethanol from blood with applications in forensic casework, *Forensic Science International* 200 (2010) 1-20
4. Alaska Administrative Code 28.35.030
5. RF Borkenstein, RF Crowther, RP Shumate, WB Ziel, and R Zylman, The Role of the Drinking Driver in Traffic Accidents, *Department of Police Administration, Indiana University, Bloomington, Indiana* (1964)
6. RD Blomberg, RC Peck, H Moskowitz, M Burns, and D Fiorentino, Crash risk of alcohol involved driving: a case-control study, *Dunlap and Associates, Inc.* (2005)

Alaska Scientific Crime Detection Laboratory

Alaska Breath Test Operator and Supervisor Manual

Issued: 05/12/2016
Effective: 05/16/2016

Version: ABTOSM 2016 R0
Status: Active

SECTION 4

EVIDENTIAL BREATH TEST INSTRUMENTS

The only approved evidential breath test instrument in the State of Alaska is the DataMaster DMT. The DataMaster DMT is manufactured by National Patent Analytical Systems, Inc. in Mansfield, Ohio.

NPAS, Inc
PO Box 1435
Mansfield, OH 44901
1-800-800-8143
www.npas.com



GENERAL FEATURES

The main features of the DataMaster DMT include a thermo-electrically cooled infrared detector to increase stability, a folded optical path length of 65 cm, a 28 mL sample cell volume, narrow bandwidth optical filters, a gray body infrared source and a mass air flow sensor. Other additional features include: a dedicated internal quartz standard of known and constant absorption allowing for repeated verification of calibration, a single point calibration, a sealed detection system, a three filter system that eliminates potentially interfering compounds, electronic options with password security and a radio frequency interference (RFI) detection system (DMT Product Overview, 2010).

EXTERNAL FEATURES

External features of the DataMaster DMT include: heated breath hose and simulator tubes; dry gas compartment with internal regulator; modem, Ethernet and USB ports; full color touch screen LCD display; calibration port; bar code reader; and RF protection both through shielding and external detection. The cover of the DataMaster DMT is made of black coated aluminum. The LCD display panel provides instructions and messages for operation of the DataMaster DMT.

Alaska Scientific Crime Detection Laboratory

Alaska Breath Test Operator and Supervisor Manual

Issued: 05/12/2016
Effective: 05/16/2016

Version: ABTOSM 2016 R0
Status: Active



(Rear Panel of the DataMaster DMT)

HOME SCREEN

The DataMaster DMT is equipped with a LCD touch screen display that is used to operate the DataMaster DMT and an external keyboard that is used for data entry. Icons and menus on the screen provide access to start all tests and change the setup of the instrument.

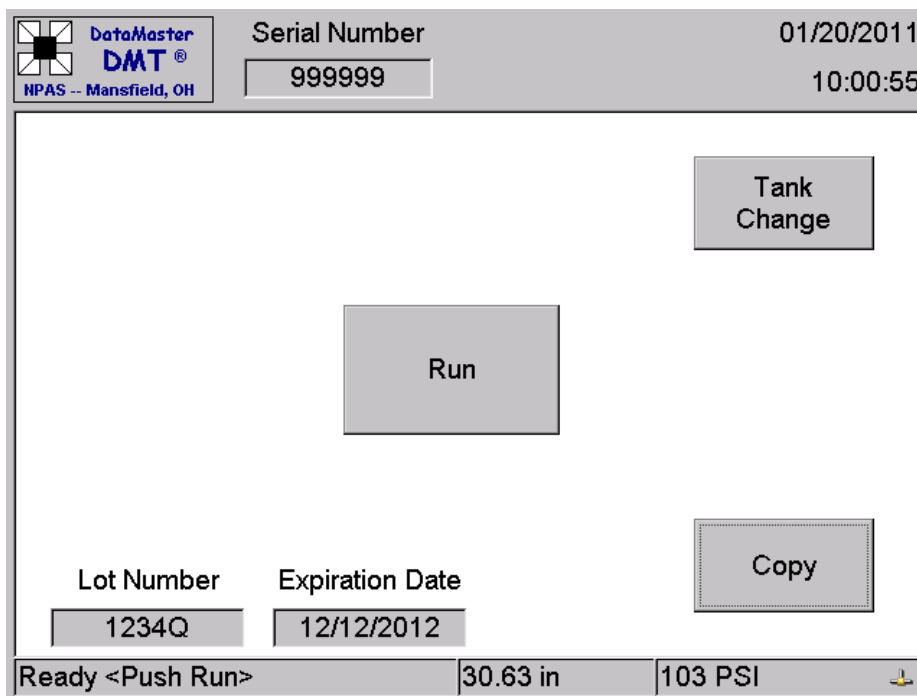

(Home Screen of DataMaster DMT)

Alaska Scientific Crime Detection Laboratory

Alaska Breath Test Operator and Supervisor Manual

Issued: 05/12/2016

Version: ABTOSM 2016 R0

Effective: 05/16/2016

Status: Active

To begin, the breath test operator or breath test supervisor should touch the screen to bring up the home screen. The home screen consists of four active blocks and several status indicator boxes. The four active blocks are as follows:

- The DMT Icon: The DMT Icon is located in the upper left hand side of the display. Touching this icon will display a drop-down menu with all the functions of the DataMaster DMT. A detailed list of these menu options is listed in the section DMT ICON MENUS.
- The RUN button: Touching the RUN button will begin a subject test.
- The COPY button: Touching the COPY button will print the last test that was conducted. If a dialog box is displayed “there is nothing to copy” no test has been conducted since the instrument was turned on.
- The TANK CHANGE button: Touching the TANK CHANGE button will prompt the operator to enter the information required when installing a new dry gas external standard and then initiate the tests utilized in the verification of calibration.

Status indicator boxes are used to indicate the status of various components of the DataMaster DMT.

- Instrument Status Box: Located in the lower left hand corner. During normal operation, this will show the “Ready” message with a flashing “Push Run” message. This will also display the countdown until ready when the instrument is warming up, change tank soon, change tank, and perform VOC when applicable.
- Barometric Pressure Reading: Located on the bottom of the home screen this box provides the station barometric pressure as measured by the DMT in inches of mercury.
- Gas Cylinder Status Box: Located on the lower right hand corner. Displays the external standard tank pressure in psi. This box turns red when the external standard tank pressure is less than 150 psi.
- External Standard Lot Number: Located above the instrument status box, this lists the lot number of the external standard in use with the instrument.
- External Standard Expiration Date: Located above the instrument status box, this lists the expiration date of the external standard in use. This box turns red when the tank expiration is within 30 days.

Alaska Scientific Crime Detection Laboratory

Alaska Breath Test Operator and Supervisor Manual

Issued: 05/12/2016
Effective: 05/16/2016

Version: ABTOSM 2016 R0
Status: Active

DMT ICON MENUS

After touching the DMT Icon menu the drop down menu will display. Items in the menu can be selected either by touching the menu option or using the corresponding keyboard key listed on the menu.

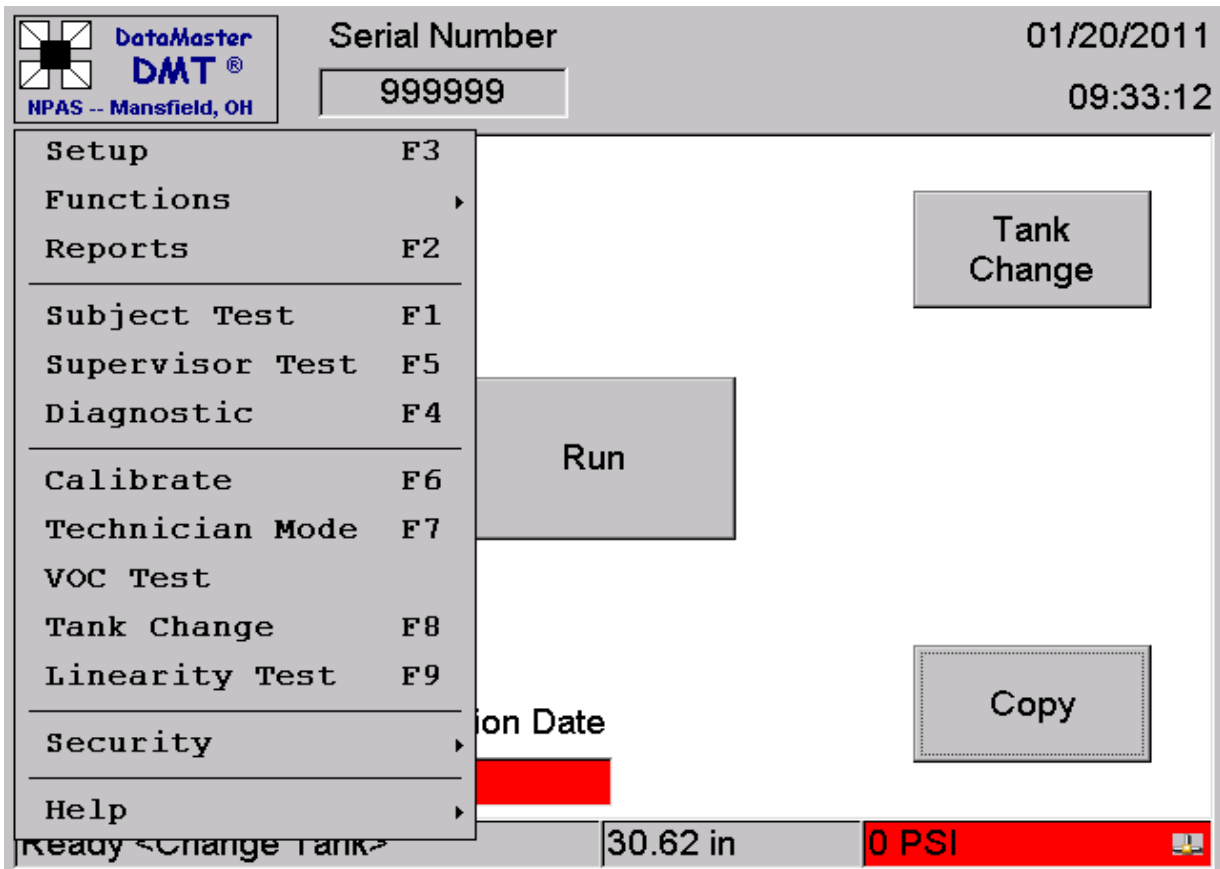

(DataMaster DMT Icon Menu)

Setup (F3)

The Setup screen contains setting for the various DMT options. A password must be entered before entering the setup screen which determines the categories and options that can be viewed and changed.

Alaska Scientific Crime Detection Laboratory

Alaska Breath Test Operator and Supervisor Manual

Issued: 05/12/2016

Version: ABTOSM 2016 R0

Effective: 05/16/2016

Status: Active

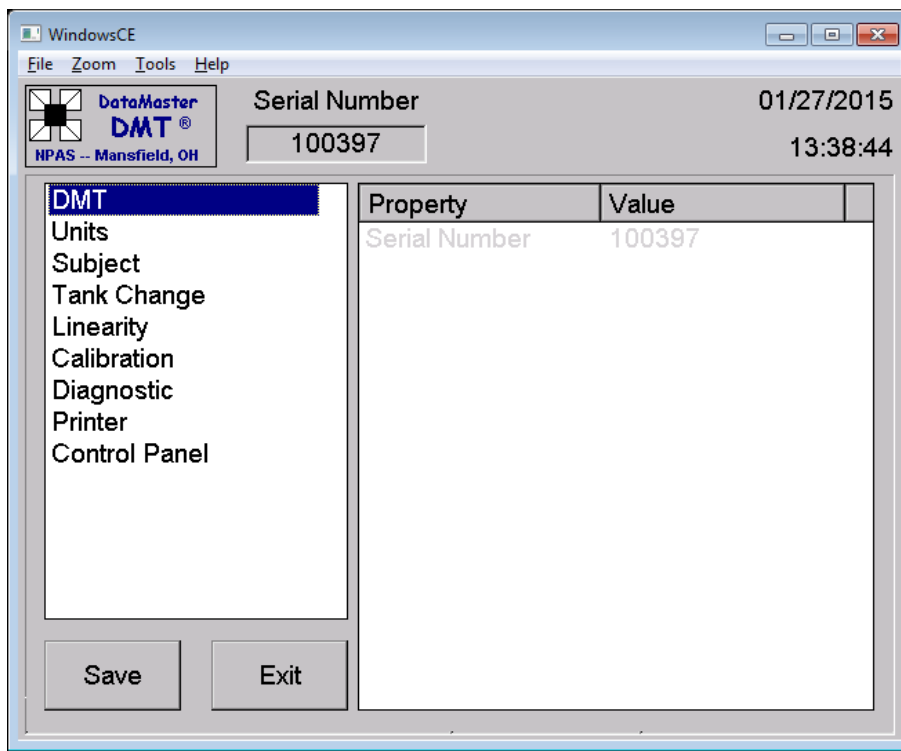

(Setup Screen for DataMaster DMT)

The options in the Setup screen are discussed below.

- **DMT:** This menu contains information on the individual instruments and is only able to be edited by the factory.
- **Units:** Lists the units that the breath alcohol is reported in (g/210 L).
- **Subject:** This menu contains information on the various options associated with a subject test including turning graphical displays on/off and the number of copies of the test strip printed. This option is only accessible to breath test supervisors. A more detailed description of these options is listed in the Subject Test Setup Options section.
- **Tank Change:** This menu contains information on the various options associated with a tank change and is not accessible to the breath test supervisor or breath test operator.
- **Printer:** This menu contains options for the external printer used with the DataMaster DMT.
- **Control Panel:** This menu contains options to run the setup for external features such as the keyboard, mouse and stylus. It is only accessible to the breath test supervisor. This option will primarily be used to calibrate the stylus for the touch screen.

Alaska Scientific Crime Detection Laboratory

Alaska Breath Test Operator and Supervisor Manual

Issued: 05/12/2016

Version: ABTOSM 2016 R0

Effective: 05/16/2016

Status: Active

Functions

From this menu the breath test operator or breath test supervisor can change the date and time display and the breath test supervisor can remove and return the instrument from and to service and import and export data from the DataMaster and purge the sample chamber.

Reports (F2)

This menu allows the breath test operator and breath test supervisor to access and print tests stored in memory. This includes prior subject tests, diagnostic tests, supervisor tests and verification of calibration reports.

Subject Test (F1)

This menu option will initiate a subject test.

Supervisor Test (F5)

This menu option is for use by the crime lab only.

Diagnostic Test (F4)

This menu option runs a diagnostic check on the DataMaster DMT. It is accessible to both the breath test operator and the breath test supervisor.

Technician Mode (F7)

This menu option opens the technician screen on the DataMaster DMT. This screen allows the breath test supervisor to view but not adjust the internal voltages and settings of the DataMaster DMT. It is not accessible to the breath test operator.

VOC Test

This menu option allows the breath test operator or breath test supervisor to initiate the tests utilized in a verification of calibration.

Tank Change (F8)

This prompts the breath test operator or breath test supervisor through dry gas external standard cylinder replacement.

Linearity (F9)

This menu option is for use by the crime lab only.

Security

This menu option allows breath test operator or breath test supervisor to log on/off of the DataMaster DMT.

Help

This menu option provides information about the instrument software versions and next automated VOC date.

Alaska Scientific Crime Detection Laboratory

Alaska Breath Test Operator and Supervisor Manual

Issued: 05/12/2016

Version: ABTOSM 2016 R0

Effective: 05/16/2016

Status: Active

SUBJECT TEST SETUP OPTIONS

The setup menu under the DMT Icon contains a screen with the various options that can be changed by the breath test supervisor for a subject test. A brief description of each of these options is as follows:

- **Ask Questions:** This option allows the breath test supervisor to turn off the data entry portion of the subject test. The default option is yes. This option should only be used for training purposes.
- **Number of Tests:** This option allows the breath test supervisor to select the number of subject tests performed in a single breath test sequence. The default option is 1 and this option should only be changed for training purposes.
- **Alcohol Display:** This option turns on and off the numerical real-time display of the subject's ethanol concentration on the bottom of the screen. The default option is yes.
- **Volume Display:** This option turns on and off the volume display at the bottom of the screen. This displays a numeric total of the subject's progress in providing the minimum volume required by the DataMaster DMT. The default option is no.
- **Graph Display:** This option turns on and off the display of the flow and alcohol graph on the screen when the subject has completed their sample. This is not displayed while the subject is blowing, only after their sample is completed. The default option is yes.
- **Graph Alcohol:** This option allows the breath test supervisor to display a real-time graph of the subject's alcohol concentration on the screen while the subject is blowing. The default option is no.
- **Graph Flow:** This option allows the breath test supervisor to display a real-time graph of the subject's breath flow rate on the screen while the subject is blowing. The default option is no.
- **Query Refusal:** This option allows the breath test supervisor to turn on a query immediately prior to the subject breath sample as to whether the subject refused. If yes is selected a test strip will print with the subject sample listed as Refused. If no is selected the subject test will proceed normally. The default option is no.
- **Wait Between Tests:** This option is not relevant with the current Alaska software. The default is set to 0.
- **Signature On:** This option turns on/off the signature option at the end of a subject test sequence. When this option is turned on the breath test operator will be asked to sign on the touch screen with the stylus to accept the subject test strip. This signature will print at the bottom of the subject test strip. The default option is yes.

Alaska Scientific Crime Detection Laboratory

Alaska Breath Test Operator and Supervisor Manual

Issued: 05/12/2016

Version: ABTOSM 2016 R0

Effective: 05/16/2016

Status: Active

- Copies: This option determines how many copies of the test strip are printed after a subject test sequence has been completed. The default option is 1.

PRINTER

The DataMaster DMT utilizes an external laser jet printer. The initial printer is provided by the crime lab. Paper, printer cartridges and replacement printers are the responsibility of the individual agencies. Contact the crime lab for more information on replacement parts or printers.

ANALYTICAL PRINCIPLES

The DataMaster DMT employs the principles of infrared spectroscopy for the purpose of measuring the level of ethanol in breath samples for forensic purposes. Infrared (IR) energy is part of the electromagnetic spectrum. It is measured in wavelength expressed as micrometers (μm). When a molecule is exposed to IR energy the bonds of the molecule will absorb the energy. Different types of molecular bonds will absorb different wavelengths of IR energy. IR energy is used by the DataMaster to detect and measure the amount of ethanol present in a breath sample. The wavelengths used are 3.37 μm , 3.44 μm and 3.50 μm .

DATAMASTER DMT SYSTEMS

The DataMaster DMT is comprised of three basic systems: the optical system, the breath/airflow system and the electronic system.

The optical system incorporates the components of the DataMaster DMT directly involved in the analysis of vapor samples for the identification and quantification of ethanol. The optical system consists of the following components:

Alaska Scientific Crime Detection Laboratory

Alaska Breath Test Operator and Supervisor Manual

Issued: 05/12/2016

Version: ABTOSM 2016 R0

Effective: 05/16/2016

Status: Active

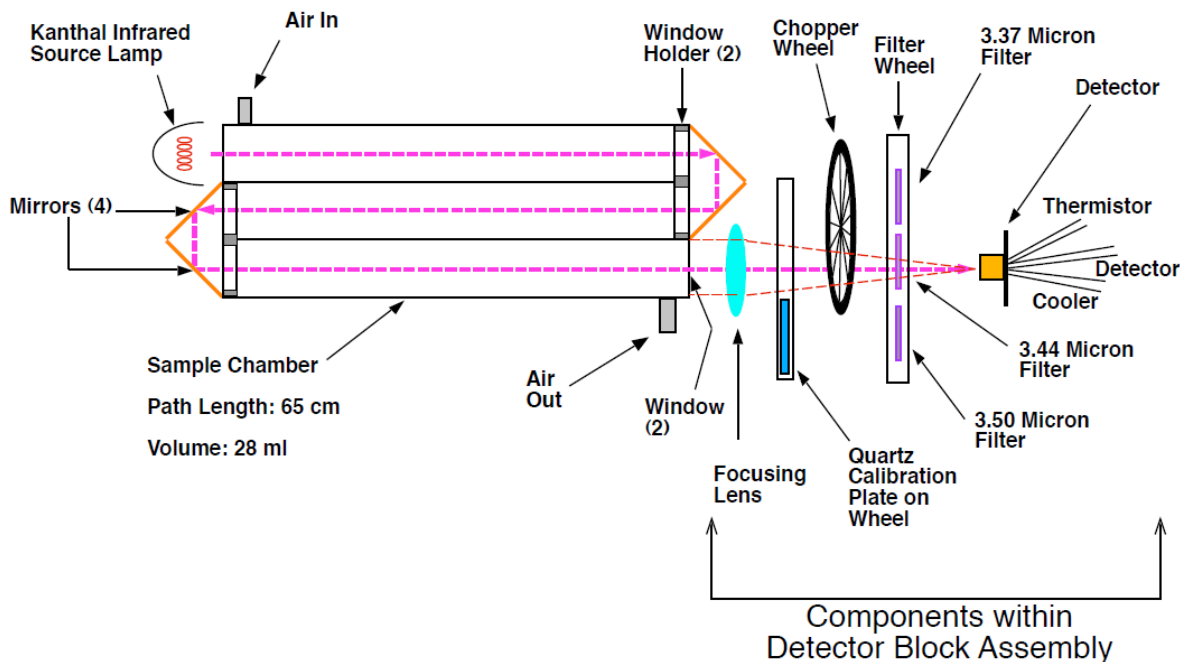

(DataMaster DMT Optical Bench)

- IR Source – emits IR energy when current passes through it
- Sample Chamber – holds approximately 28 mL of vapor, heated to 50°C +/- 5°C, and is folded to a total length of 65 cm
- Mirrors – located at both folds of the sample chamber for the purpose of reflecting IR energy
- Focusing Lens – the IR energy is focused onto the surface of the detector by a lens located in the detector block
- Chopper Wheel – interrupts the light energy as it is being focused on the detector allowing for separation and amplification of the IR energy
- Filters – The IR energy exiting the sample chamber is filtered through three filters (3.44, 3.37, and 3.50 μm)
- Calibration Plate (Internal Standard) – 1 mm thick piece of quartz that is moved into the optical path when the internal standard check is performed
- Detector – made of lead selenide (PbSe) and is typical for applications in the 2 - 5 μm range

Alaska Scientific Crime Detection Laboratory

Alaska Breath Test Operator and Supervisor Manual

Issued: 05/12/2016

Version: ABTOSM 2016 R0

Effective: 05/16/2016

Status: Active

DMT-G
Airflow Block Diagram

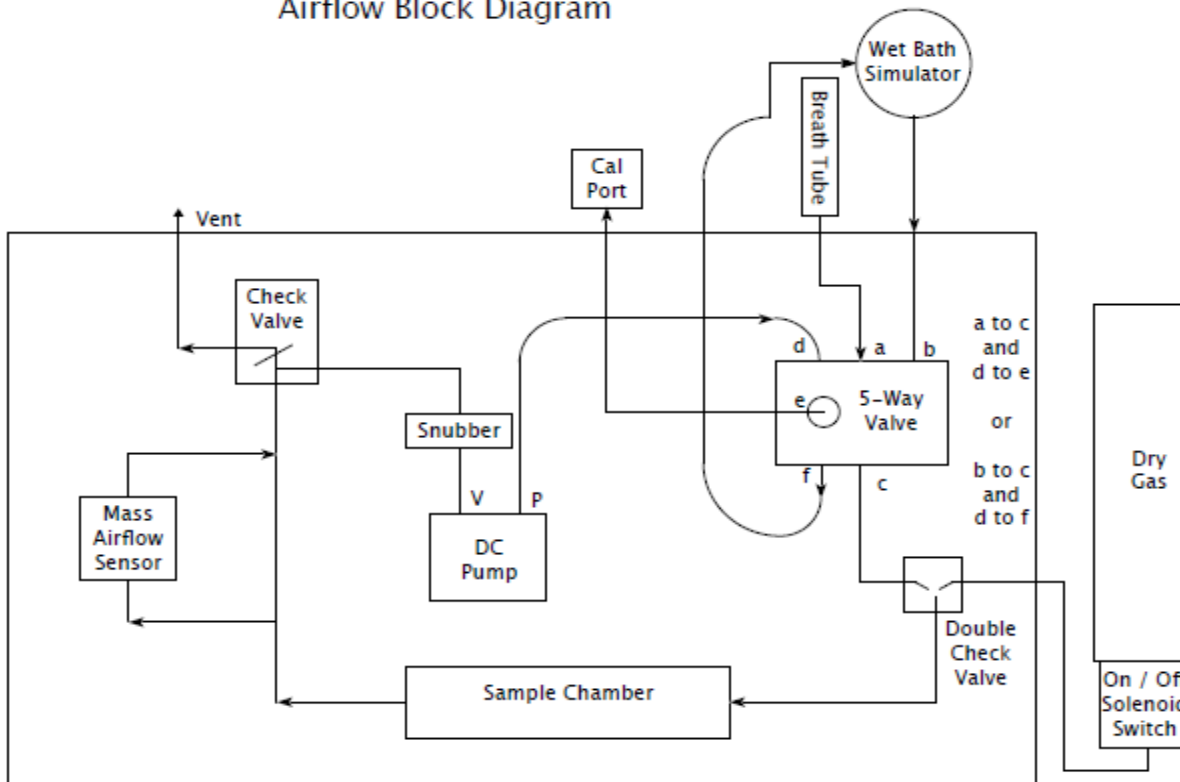

The breath/airflow system describes the mechanism of the DataMaster DMT that moves vapor samples in and out of the sample chamber and also purges the sample chamber with fresh air. It is comprised of the following components:

- Heated External Breath Hose
- Internal Breath Tubing – provides a pathway for vapor samples and room air to circulate between the breath hose, the intake of the control sample ports, the sample chamber and outlet ports
- 5-Way Valve – an internal valve that controls the airflow path through a series of signals sent from the microprocessor
- Sample Chamber
- Pump – a single pump that creates a vacuum/pressure that will draw or push air through the system
- Snubber – a pneumatic capacitor that levels out airflow produced by the pump, reduces air fluctuations and helps the check valve remain closed
- Check Valve – a white fitting located within the airflow pathway that only allows air flow in the proper direction
- Calibration Port
- Simulator Inlet and Outlet Ports

Alaska Scientific Crime Detection Laboratory

Alaska Breath Test Operator and Supervisor Manual

Issued: 05/12/2016

Version: ABTOSM 2016 R0

Effective: 05/16/2016

Status: Active

The electronic system includes the power supply, microprocessor and controller board along with other components which interact as necessary to allow the instrument to function as designed and interact with the user. The DataMaster DMT utilizes a Windows CE operating system in conjunction with DMT software.

Alaska Scientific Crime Detection Laboratory

Alaska Breath Test Operator and Supervisor Manual

Issued: 05/12/2016
Effective: 05/16/2016

Version: ABTOSM 2016 R0
Status: Active

SECTION 5

SUBJECT TESTS

It is essential that breath test operators and breath test supervisors follow the proper procedures when administering a breath test. The subject should be carefully observed during the breath test so his/her actions, demeanor, and behavior can be documented.

PRE-TEST PROCEDURES

Radios should be turned off in the vicinity of the testing area whenever possible. This is to avoid the possibility of a RFI DETECTED status message that would abort the subject test. The testing area should be free from organic solvents and fumes, including exhaust fumes. When feasible subjects should be kept away from the breath test instrument except when they are providing a breath sample.

13 AAC 63.040. Procedure for breath test analysis

(a) The following procedure must be used to obtain and analyze a breath sample on a breath test instrument:

- (1) observe the person to be tested for at least 15 minutes immediately before testing, to ensure that the person does not regurgitate or place anything in his or her mouth during that period;*
- (2) respond to the visual display on the instrument by entering the data requested;*
- (3) when the visual display indicates that the instrument is ready to accept the person's breath sample, instruct the person to blow into the mouthpiece until the visual display indicates that a satisfactory sample has been obtained.*

(b) Only a person certified as an operator under 13 AAC 63.050 may operate a breath test instrument, except that a supervisor may supervise the use of an instrument by a non-certified person for training or demonstration purposes.

INSTRUMENT PREPARATION

The DataMaster should display READY in the instrument status box. The operator should verify that the time and date display is accurate on the DataMaster and correct if necessary using the Set Date and Time feature under Functions of the DMT Icon Menu. The breath test operator should supply a new mouthpiece for each breath testing sequence.

SUBJECT TEST SEQUENCE

The breath test operator touches the RUN button to initiate a subject test. The breath test operator then selects the test type and either scans the subject's operator license using the barcode scanner or types in the requested information. If the test type Test is selected the subject name field will be prepopulated with Test, Test. The operator also has the option to press "scan operator card" and scan their breath test operator card, similar to how the

Alaska Scientific Crime Detection Laboratory

Alaska Breath Test Operator and Supervisor Manual

Issued: 05/12/2016

Version: ABTOSM 2016 R0

Effective: 05/16/2016

Status: Active

driver's license can be scanned, and their name and operator number will be pulled from the barcode.

TEST TYPES:

DUI

Minor consuming

Other

Test

SUBJECT'S NAME:

The breath test operator enters the full name of the subject being tested.

O.L.#

The breath test operator enters the driver's license number of the subject.

OPERATOR'S NAME:

The breath test operator types in his/her name or scans breath test operator card.

OPERATOR'S NUMBER:

The breath test operator enters the number assigned to him/her or scans breath test operator card.

DEPT/AGENCY:

The breath test operator enters the 4-character code indicating the agency he/she works for.

CASE/REPORT:

The breath test operator enters the agency case number.

The breath analysis portion of the test is automatic. Once in progress the breath test operator cannot alter the outcome of the test. The breath test operator's duty from this point is to instruct the subject how and when to provide a breath sample. The breath test operator should provide a new mouthpiece for each subject test sequence. The following are descriptions of each portion of the subject test:

DIAGNOSTIC CHECK

Voltages and temperatures of the instrument are checked to ensure they fall within the tolerances allowed. A passing test reads PASSED on the test strip.

PURGING AND AMBIENT TESTING

All chambers and internal plumbing are cleansed of any residual volatile substances by room air. Room air is pulled through the breath tube and pumped throughout the instrument by an internal pump. During the purging process the instrument takes two measurements of the detector voltage that must agree within prescribed tolerance. If the measurements don't agree the test aborts with an AMBIENT FAIL status message.

Alaska Scientific Crime Detection Laboratory

Alaska Breath Test Operator and Supervisor Manual

Issued: 05/12/2016

Version: ABTOSM 2016 R0

Effective: 05/16/2016

Status: Active

AMBIENT ZEROING

The DataMaster determines zero references based on ambient air in the sample chamber. Each of the three filters is inserted into the IR path to establish a zero reference at each wavelength.

BLANK TEST

A measurement is taken after the AMBIENT ZEROING phase of the operation. This ensures the sample chamber is clear before the subject sample.

INTERNAL STANDARD CHECK

A quartz plate is inserted into the IR path to assure that the accuracy of the DataMaster has not changed since the last calibration.

EXTERNAL STANDARD

A sample of an ethanol dry gas standard is pulled through the gas line into the sample chamber, the sample is analyzed and the results are displayed.

PURGING

AMBIENT ZEROING

BLANK TEST

PLEASE BLOW

The subject provides a sample of their breath. An intermittent beeping sound will be heard until a breath sample is provided with a sufficient flow rate to satisfy the requirements of the sampling system. The subject has two minutes to provide an adequate sample. As they blow through the instrument a measurement is taken four times per second. Once the subject sample requirements have been met and the subject stops blowing the final portion of the breath is captured and analyzed.

TEST RESULTS

The measured ethanol result is calculated.

PURGING

AMBIENT ZEROING

BLANK TEST

EXTERNAL STANDARD

PURGING

AMBIENT ZEROING

BLANK TEST

Alaska Scientific Crime Detection Laboratory

Alaska Breath Test Operator and Supervisor Manual

Issued: 05/12/2016
Effective: 05/16/2016

Version: ABTOSM 2016 R0
Status: Active

If the signature option is turned on a screen will appear for the breath test operator to add an electronic signature to the bottom of the test strip. After the breath test operator has signed and pressed accept the subject test results print automatically and test results are stored into memory. These tests can be accessed using the reports menu accessed thru the DMT Icon. The crime lab uploads data files periodically. If the test strip fails to print or an error occurs during printing the breath test operator should press the COPY button which will print the last test in the memory. Following the printing of the test strip the breath test operator should verify that the test completed.

The DataMaster DMT has a graphical display option that graphs both the subject's breath flow rate and breath alcohol concentration. This graph is included on the test strip printout. The x-axis of the graph is the time in seconds while the y-axis is the breath flow rate in liters per minute. The dotted line represents the duration of the subjects blow as well as flow rate. The solid black line indicates the subject's alcohol level. The minimum flow rate is denoted by a horizontal line on the graph at 3 liters per minute. The y-axis does not include alcohol levels to correspond with the curve. If the subject test has completed the result of the test will be printed on the left hand side of the subject test print out next to "subject test" in units of grams per 210 L.

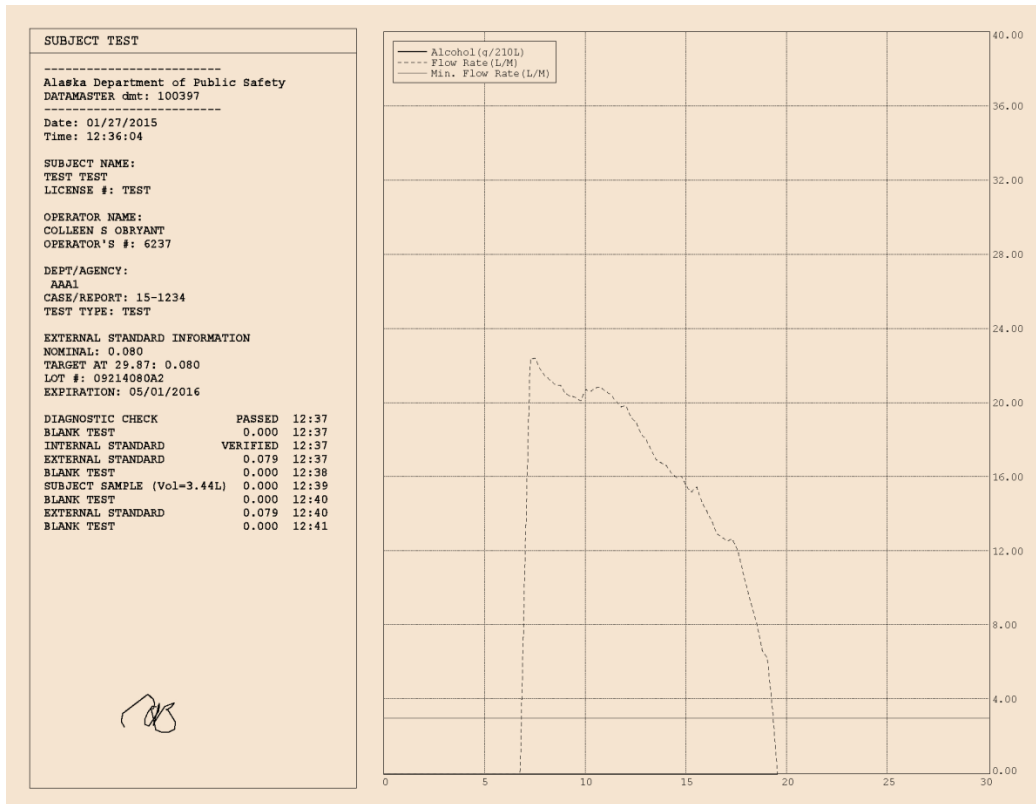

Alaska Scientific Crime Detection Laboratory

Alaska Breath Test Operator and Supervisor Manual

Issued: 05/12/2016

Version: ABTOSM 2016 R0

Effective: 05/16/2016

Status: Active

REPORTS

The reports menu under the DMT icon allows the breath test operator and supervisor to access and print tests that are stored in memory. If a copy of a previously performed test needs to be printed it can be found under the reports menu. The most recent test in memory can be printed by pressing the COPY button on the home screen.

SAMPLE ACCEPTANCE PARAMETERS

The DataMaster accepts a breath sample after the subject has provided a sample into the breath hose and the sample provided has met the necessary criteria for analysis.

A breath sample is accepted when it meets the following criteria:

- A minimum flow rate is required. For the duration of the blow the flow rate must not drop below the minimum requirements. The minimum flow rate is 3 L/min.
- A minimum volume of breath is required. The minimum volume is approximately 1.5 L.
- Ten or less attempts where the subject's breath flow exceeds and drops below the minimum flow rate.
- The breath alcohol profile must have reached a plateau.
- Negative slope parameters must be met.
- The flow rate must fall below minimum requirements for the sample to be accepted.

NON-COMPLETED TESTS

When a status message occurs the subject test sequence will stop. A dialog box will appear describing the status message and the operator will be prompted to restart the test. When the status message occurs after the subject has provided a breath sample, the subject's breath alcohol result will be printed as "XXX".

Alaska Scientific Crime Detection Laboratory

Alaska Breath Test Operator and Supervisor Manual

Issued: 05/12/2016

Version: ABTOSM 2016 R0

Effective: 05/16/2016

Status: Active

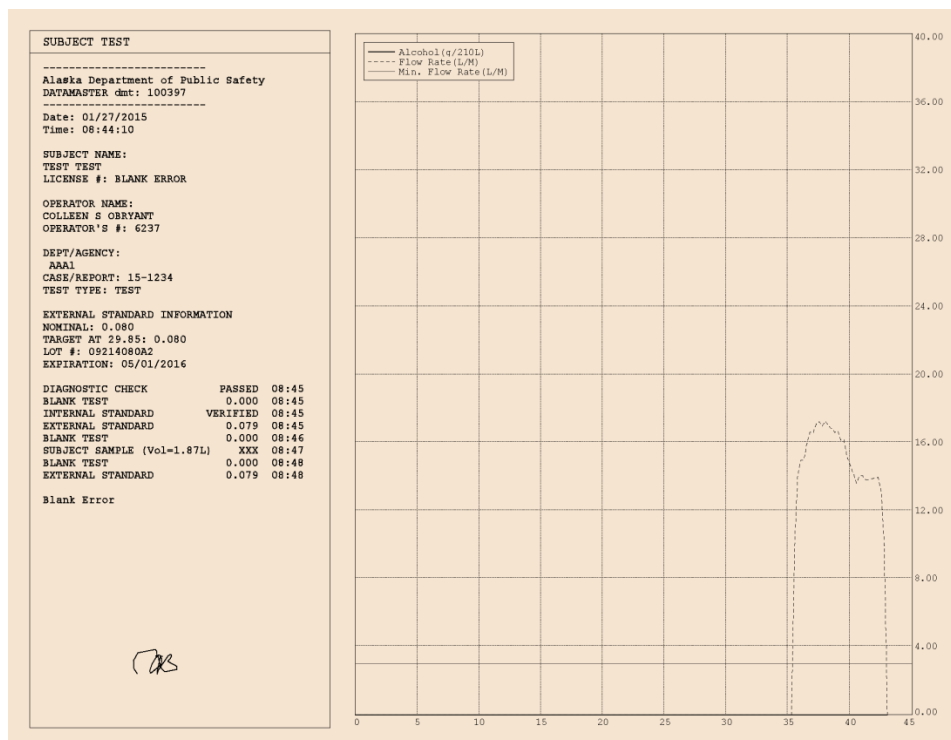

EXTERNAL STANDARDS

The external standard delivers a known quantity of ethanol to the DataMaster both before and after the subject sample. The purpose is to ensure the DataMaster is accurately recognizing and quantitating ethanol concentrations.

The external standards currently in use with the DataMaster DMT are commercially prepared cylinders. Each cylinder will have a label affixed which contains the lot number and expiration date of the cylinder.

The DataMaster DMT uses an internal regulator to regulate the flow of gas into the instrument. The regulator activates automatically so there is no need for the breath test operator to turn the cylinder on or off. The pressure reading for the cylinder is displayed in the lower right hand corner of the home screen. When the pressure reads 150 psi the color of the box will change to red and at 100 psi the instrument will no longer allow a subject test to be performed until the cylinder is changed.

To exchange a cylinder, open the door on the cylinder compartment and twist the existing cylinder counter-clockwise until the tank is free of the regulator. The breath test operator should then press the TANK CHANGE button on the home screen.

Alaska Scientific Crime Detection Laboratory

Alaska Breath Test Operator and Supervisor Manual

Issued: 05/12/2016

Version: ABTOSM 2016 R0

Effective: 05/16/2016

Status: Active

Supervisor Information

Name(F/M/L) JOHN Q TEST

Certificate # 12345TEST

Control Information

Lot # 1234QWERTY

Expiration Date 12/12/2012

Cancel OK

(Tank Change Screen on the DataMaster DMT)

This will bring up a window prompting the breath test operator to enter his/her name and operator number and the lot number and expiration date of the external standard cylinder. This information should be read directly from the new cylinder prior to inserting it into the dry gas compartment. The breath test operator will then be asked to verify the lot number and expiration date entry by reentering the information. If the entries do not match the breath test operator will be asked to reenter the information. After the information is entered correctly the breath test operator will be prompted to ensure the cylinder is correctly installed in the dry gas compartment. The instrument will then initiate the tests utilized in a verification of calibration. The breath test operator will not be able to begin a subject test until this has successfully completed.

The lot number and expiration date entered by the breath test operator or supervisor will be the lot number and expiration date printed on the subject test performed using this external standard cylinder. It is important that the breath test operator ensure the lot number and expiration date are entered correctly.

The DataMaster DMT will also display the external standard lot number and expiration date on the home screen. The box housing this information will change color to red when the external standard is 30 days from its expiration date. The DataMaster will not allow a subject test to be performed with an expired cylinder.

Replacement external standard cylinders need to be requested from the crime lab. Breath test supervisors are responsible for making these requests. Breath test operators should notify the breath test supervisors if their agency is in need of replacement cylinders.

Alaska Scientific Crime Detection Laboratory

Alaska Breath Test Operator and Supervisor Manual

Issued: 05/12/2016

Version: ABTOSM 2016 R0

Effective: 05/16/2016

Status: Active

SECTION 6

QUALITY ASSURANCE

INTRODUCTION

There are numerous measures that are taken to ensure the quality of each breath sample. External standards, internal standards and blank tests are performed with each breath sample. A verification of calibration is performed at least every 60 days and when the external standard is changed.

QUALITY ASSURANCE MEASURES

A diagnostic check is performed at the beginning of each subject test sequence. The diagnostic check is a self-check of the instrument voltages and temperatures.

A blank test follows each purging cycle to verify the sample chamber is clear prior to taking a measurement.

The internal standard is a quartz plate that is inserted into the IR path to demonstrate the accuracy of the instrument has not changed since the last calibration. Each instrument stores in memory the IR absorption value of this quartz standard at the time of calibration. The measurement of the quartz plate at the time of the test is compared to the stored value and must agree within prescribed limits or the test will be aborted.

The external standard is a metal cylinder containing a mixture of ethanol and an inert gas under pressure. The external standard cylinder is connected to the instrument through an internal regulator. External standards deliver a known quantity of ethanol to the instrument at specific times in the breath test procedure. This is done to test the ability of the instrument to accurately recognize and quantitate ethanol. The allowable range for the external standard is +/- 0.005 from the target value adjusted for barometric pressure.

A verification of calibration on the DataMaster DMT consists of a diagnostic test, which is a self-check of the instrument and five tests of the external standard. These tests are initiated by the instrument's software and printed on the verification of calibration report. These reports are approved by the scientific director. Verification of calibration reports are required to be performed at least every 60 days or whenever the external standard cylinder is changed. The crime lab has selected a list of days throughout the year that will meet the 60 day requirement and allow for the verification of calibration schedule to be more uniform. The selected days for verification of calibrations are as follows:

January 3rd
February 21st
April 11th
May 30th

July 18th
September 5th
October 24th
December 12th

Alaska Scientific Crime Detection Laboratory

Breath Alcohol Testing Program Manual

Issued: 1/7/2013

Effective: 1/7/2013

Version: BATPM2013 R0

Status: Active

The instrument software will initiate the tests utilized in the verification of calibration on each instrument on each of these days at 12:00 pm. The reports will be uploaded by the crime lab and approved by the scientific director. The dates provided above are not required dates for verifications of calibrations. The only date requirement is that a verification of calibration be performed every 60 days. Verifications of calibrations will also be performed automatically with each external standard cylinder replacement.

Records of these documents are kept in the normal course of business at the crime lab.

Alaska Scientific Crime Detection Laboratory

Alaska Breath Test Operator and Supervisor Manual

Issued: 05/12/2016

Version: ABTOSM 2016 R0

Effective: 05/16/2016

Status: Active

SECTION 7

BREATH TEST SUPERVISOR DUTIES

DUTIES AND RESPONSIBILITIES OF BREATH TEST SUPERVISORS

Breath test supervisors are responsible for performing the following duties at their agencies:

- Instructing fellow officers how to operate the evidential breath testing instrument and how to properly administer a breath test.
- Setting up, performing routine maintenance and troubleshooting his/her instrument.
- Ordering external standards and other breath testing supplies.
- Maintaining the paperwork associated with breath test operators he/she has instructed. This includes informing the crime lab when breath test operators relocate or change names.
- Communicate with the crime lab about instrument issues, operator status or questions about paperwork. The preferred method for sending paperwork is to the program general email: dps.scdl.toxicology@alaska.gov
- Maintain and submit to the crime lab paperwork associated with the instrument.
- Timely response to all communications from the breath alcohol program.
- Breath test supervisors may be asked to perform other duties or take on additional responsibilities depending on individual circumstances.
- Ensuring the instrument is turned on and connected to a dedicated modem line when the instrument is in service.

BREATH TEST INSTRUMENT TRANSPORT TO AND FROM AGENCIES

Breath testing equipment is shipped to agencies from the crime lab. The crime lab pays for the outgoing shipping on instruments, supplies and external standards. When instruments are to be shipped commercially they will be placed in an approved shipping case. A list of instructions to the breath test supervisor regarding instrument care will be included inside the shipping case. If the instrument received was intended to replace an existing instrument, package the previous instrument in a similar manner and return to the crime lab. If there is not a return instrument, the agency must return the empty case to the crime lab.

Individual agencies are responsible for return shipment of instruments, supplies, and shipping cases to the crime lab. Agencies may use the most cost effective means to ship the equipment. For information on disposal of empty external standard cylinders please contact the crime lab. Do not return the empty cylinders to the crime lab. It is recommended that the supervisor notify the crime lab regarding any shipping information (carrier, waybill information, date shipped) when equipment is returned.

BREATH TEST INSTRUMENT SET-UP

The following instructions are general guidelines for receiving and setting up an evidential breath testing instrument for operation.

1. Let the instrument sit for several hours or overnight so it can warm to room temperature.

Alaska Scientific Crime Detection Laboratory

Alaska Breath Test Operator and Supervisor Manual

Issued: 05/12/2016

Version: ABTOSM 2016 R0

Effective: 05/16/2016

Status: Active

2. Make sure that an APC line voltage regulator unit is present and set up according to the instructions with the unit. (APCs are supplied by the crime lab.)
3. Attach the breath hose and modem line.
4. Plug the instrument into the prepared APC unit, turn it on and allow it to warm up.
5. Connect the external printer and ensure it is turned on and contains paper.
6. When a dialog box appears regarding the printer driver, press the "X" at the top of the dialog box to close it. DO NOT PRESS "OKAY".
7. Press the TANK CHANGE button and follow the instrument prompts for installing the external standard cylinder.
8. After the instrument has completed the verification of calibration fill out a change in instrument status form to put the instrument in service.

The breath test supervisor can change various settings on the DataMaster according to the individual agency's preference. Examples of settings that can be changed include: the number of copies of the test strip printed, whether the alcohol value is displayed during the subject blow, the use of the refusal query and whether the graphical displays are on or off. A detailed description of these options is listed under Subject Test Setup Option in the Evidential Breath Test Instrument section.

Once the instrument is in service it is the responsibility of the breath test operators and supervisors of the agency to ensure the date and time of the instrument are correct. Date and time settings are not routinely monitored by the crime lab once an instrument has been placed in service.

The breath test supervisor can restore the default settings by selecting reset options from the Function menu under the DMT Icon.

INSTRUMENT LOCATION

It is important that the evidential breath test instrument location is secure. The power source should be of good quality and the instrument plugged into an APC supplied by the crime lab. Contact the crime lab for replacement APC units or replacement batteries.

In order to purge the sample chamber between tests the DataMaster requires that clean air is flushed through the sample chamber. A symptom of a poorly ventilated testing area is the occurrence of multiple AMBIENT FAIL status codes.

High room temperatures can cause operational problems for the instruments. A symptom of an overheated room is multiple AMBIENT FAIL status messages. It is essential that the rear of the instrument is not blocked.

The RFI detector located in the breath hose will cause a test to abort if radio frequency is detected within the immediate area. The RFI detector sensitivity is verified by the breath alcohol program during instrument certification. The breath hose should not be replaced in the field

Alaska Scientific Crime Detection Laboratory

Alaska Breath Test Operator and Supervisor Manual

Issued: 05/12/2016

Version: ABTOSM 2016 R0

Effective: 05/16/2016

Status: Active

because the RFI sensitivity for the instrument could change. All radios in the vicinity of the instrument should be turned off, if possible, when a DataMaster test is in progress or the test could abort with a RFI DETECTED status message.

Agencies are required to provide a dedicated telephone line for use with the DataMaster. Subject test data is uploaded to a host computer located in the crime lab. The uploading process is initiated by the crime lab. The crime lab can also remotely access the instruments for troubleshooting purposes.

OPERATOR TRAINING

Alaska Administrative Code requires that all breath test operators complete a four hour course of instruction approved by the scientific director. Breath test supervisors provide this instruction at their agency. The curriculum of the course must include four hours of instruction in the theory of alcohol physiology, toxicology, pharmacology, instrument maintenance, practical operation and administrative procedures.

The breath program provides the approved breath test operator training program (powerpoints, activities, and exam) to the breath test supervisors. This is the only training that may be taught.

At the completion of the course the operator must take and pass, with a 75 percent or greater, the approved written examination. The approved breath test operator exam and key is available through the breath alcohol program. Upon successful completion of the course, the breath test supervisor will complete the Request for Change in Operator Certification/Recertification form and submit it to the crime lab. The breath test operator will be issued a certificate and operator number from the scientific director which expires at 11:59 p.m. on December 31 of the third year after the year issued.

Breath test supervisors are also responsible for teaching recertification courses to breath test operators. Per Alaska Administrative Code the recertification must be completed during the period of the breath test operator's certification. It must contain at least four hours of instruction and training and they must pass the written examination with a 75 percent or greater. After completion of the course the breath test supervisor must complete the Request for Change in Operator Certification/Recertification form and submit it to the crime lab. The breath test operator will be issued a new operator card by the scientific director which expires at 11:59 p.m. on December 31 of the third year after the year issued.

SUPERVISOR PAPERWORK

Change in Instrument Status Form

The breath alcohol program keeps a record of all maintenance and movement of the DataMaster instruments. Breath test supervisors should notify the crime lab of any change in status of the instrument(s) at their agency by filling out a Change in Instrument Status Report and submitting it to the crime lab.

Alaska Scientific Crime Detection Laboratory

Alaska Breath Test Operator and Supervisor Manual

Issued: 05/12/2016

Version: ABTOSM 2016 R0

Effective: 05/16/2016

Status: Active

The following situations would require a Change in Instrument Status Form to be filled out by the breath test supervisor:

1. Placing an instrument in service or removing an instrument from service.
2. The relocation of an instrument to a new building.
3. Documenting instrument issues to the breath alcohol program.

The completed Change in Instrument Status Form should be sent to the crime lab where they will be entered into the instrument file.

Change in Operator Status Form

The breath alcohol program keeps a database of breath test operator information. To keep the database as accurate as possible, breath test supervisors are asked to submit a Change in Operator Status form whenever a breath test operator's status changes with regards to the breath alcohol program. E-mail notification is also acceptable.

Situations that would require a Change in Operator Status form include: a breath test operator is hired at an agency, a breath test operator's employment is terminated at an agency, a breath test operator transfers to a different agency or location in the state or a breath test operator changes their name.

Request for Certification/Recertification of Breath Test Operators Form

The breath alcohol program requires breath test supervisors to complete a Request for Certification/Recertification of Breath Test Operators Form after training breath test operators at their agency.

The crime lab issues breath test operator cards upon receipt of the Request for Certification/Recertification of Breath Test Operators form. The cards contain the breath test operator name, certification number, expiration date, and signature of the scientific director. The breath test operator should keep his/her card in his/her possession. Another breath test operator card will be issued when the operator completes a recertification.

Breath test operator cards are mailed to the instructor of the Certification or Recertification course. It is the responsibility of the breath test supervisor who submitted the Request for Certification/Recertification of Breath Test Operators Form to distribute the cards to the individual breath test operators. If this is not possible it is the responsibility of the breath test supervisor to communicate with the crime lab about where the cards should be sent.

ORDERING SUPPLIES FROM THE BREATH ALCOHOL PROGRAM

The breath alcohol program supplies many of the consumables related to breath testing. These include:

- Mouthpieces for the DataMaster
- Replacement External Standard Cylinders

Alaska Scientific Crime Detection Laboratory

Alaska Breath Test Operator and Supervisor Manual

Issued: 05/12/2016

Version: ABTOSM 2016 R0

Effective: 05/16/2016

Status: Active

The crime lab provides the initial external printer used with the DataMaster DMT. Replacement printer cartridges, paper and printers are the responsibility of the individual agency. The breath test supervisor can contact the crime lab for information on which printers are compatible with the DataMaster DMT.

Replacement cylinders and supplies can be ordered by e-mail or phone.

E-mail requests should be sent to dps.scdl.toxicology@alaska.gov.

Phone requests (907) 269-5592

To minimize shipping costs for external standard cylinders please give the crime lab 3-4 weeks to send replacement external standard cylinders.

PROBLEM RESOLUTION (TROUBLESHOOTING)

Problems with the DataMaster stem from a variety of sources and may or may not reflect an underlying instrument malfunction. Problems with DataMaster operation are generally indicated by a status message. Some of the more common status messages are described below. A table is included with a list of status messages along with suggestions on how to address the problem.

Ambient Fail

Generally, this is an environmentally caused status message due to inadequate air quality in the vicinity of the instrument.

Maximum Attempts Exceeded

This status message indicates the subject provided 10 incomplete attempts during the allotted two minute window. An attempt is when the subject's breath flow exceeds and drops below the minimum flow rate.

Incomplete

This indicates that the subject did not provide a sample that met the minimum flow and volume requirements within the two minutes allotted.

Invalid

This indicates the instrument detects a series of negative slopes, exceeding the allowable amount, in the breath profile provided by the subject.

Interference

Generally, indicates the presence of a substance other than ethanol present in the subject's breath sample.

Alaska Scientific Crime Detection Laboratory

Alaska Breath Test Operator and Supervisor Manual

Issued: 05/12/2016

Version: ABTOSM 2016 R0

Effective: 05/16/2016

Status: Active

Subject Sample XXX

All quality assurance measures both before and after the subject breath sample must pass in order for the subject's breath alcohol result to be reported. When this does not occur the subject sample is reported as "XXX". Any breath values viewed by the operator during the subject test of a test resulting in an XXX will not be supported by the Breath Alcohol Program.

RFI Detected

This status message indicates the radio frequency detector in the breath hose of the instrument detected the presence of radio interference the vicinity of the instrument. Usually occurs when a radio transmits in the vicinity of the instrument.

Standard Out of Range

This indicates that the external standard reading was outside of the allowable tolerance (+/- 0.005) from the external standard target value adjusted for barometric pressure.

Status Message	How to Address the Problem
Ambient Fail	<ol style="list-style-type: none">1. Remove the subject from vicinity of the DataMaster (try test again)2. Ventilate the room3. Purge the sample chamber4. Perform a non-drinking subject test5. If ambient fail persists contact crime lab
Blank Error	<ol style="list-style-type: none">1. Remove the subject from vicinity of DataMaster2. Ventilate the room3. Purge the sample chamber4. Perform a non-drinking subject test5. If blank error persists contact crime lab
Breath Tube Temperature Check	<ol style="list-style-type: none">1. Ensure breath tube is connected properly2. Run diagnostic to find breath hose temperature3. Remove the breath hose from the cover if it is too hot4. If the message persists contact the crime lab
Detector Overflow	<ol style="list-style-type: none">1. If the status message occurs during a subject test attempt a second test.2. If the status message occurs at a time when a subject is not being tested, contact the crime lab
Fatal System Error	<ol style="list-style-type: none">1. Retry the subject test.2. Contact your agency's supervisor even if the status message does not reoccur.3. Supervisor should contact the crime lab.

Alaska Scientific Crime Detection Laboratory

Alaska Breath Test Operator and Supervisor Manual

Issued: 05/12/2016

Version: ABTOSM 2016 R0

Effective: 05/16/2016

Status: Active

Filter Wheel Error	<ol style="list-style-type: none">1. Attempt to run a filter test (under functions) and see if the filter will realign itself.2. Reboot instrument.3. If message persists contact the crime lab.
Filter 1, 2 or 3 Won't Zero	<ol style="list-style-type: none">1. Reboot instrument.2. If status message persists contact crime lab.
Heated Simulator Tube Temperature Check	<ol style="list-style-type: none">1. Contact the crime lab.
Incomplete	<ol style="list-style-type: none">1. Restart test once and instruct subject to blow until they are out of air.2. If subject seems to be attempting to provide a sample and is having difficulty, attempt a non-drinking subject test to determine the ability of the instrument to accept a sample.3. Contact the crime lab if there seems to be a problem with the instrument sample acceptance.
Interference	<ol style="list-style-type: none">1. Ensure the instrument has had sufficient time to warm up if it was only recently put into service.2. Restart test once, direct subject to provide a sample steadily.3. If INTERFERENCE status message occurs twice in a row on the same subject, who appears to be blowing properly, get a search warrant for blood.4. If INTERFERENCE status message occurs with unusual frequency, contact crime lab (breath test supervisors)
Internal Standard Error	<ol style="list-style-type: none">1. Reboot instrument.2. Contact the crime lab if the message persists.
Invalid Sample	<ol style="list-style-type: none">1. Restart test once, direct subject to provide a sample steadily. Watch for inappropriate blowing behavior such as: blowing around the mouth piece, blocking mouthpiece with tongue, etc.2. If Invalid Sample status message occurs with unusual frequency, contact crime lab (breath test supervisors)
Maximum Attempts Exceeded	<ol style="list-style-type: none">1. Restart the test and instruct the subject to with one long steady breath. Watch for the subject to start and stop instead of providing one steady breath.
Pump Error	<ol style="list-style-type: none">1. Check mouthpiece, check valve and breath hose screen for blockage.2. Remove breath hose from instrument and blow through it.5. If Pump Error persists, contact crime lab
RFI Detected	<ol style="list-style-type: none">1. Locate the source of the RF interference (radio in operation in vicinity of DataMaster) and remove from vicinity. Restart test.2. If RFI Detected persists, contact the crime lab

Alaska Scientific Crime Detection Laboratory

Alaska Breath Test Operator and Supervisor Manual

Issued: 05/12/2016
Effective: 05/16/2016

Version: ABTOSM 2016 R0
Status: Active

Sample Chamber Temperature Check	<ol style="list-style-type: none"> 1. Reboot the instrument. 2. If the message persists contact the crime lab.
Simulator Time Out	<ol style="list-style-type: none"> 1. Restart test once. 2. If message persists contact the crime lab.
Standard Deviation Error	<ol style="list-style-type: none"> 1. Contact the crime lab.
Standard Out Of Range	<ol style="list-style-type: none"> 1. Restart test once. 2. Check the barometer reading with the barometric pressure for your area, if barometer is out of range call the crime lab. 3. If Standard Out of Range status message persists, contact the crime lab.
Suck Back Error	<ol style="list-style-type: none"> 1. Restart test once and instruct subject not to suck back air thru the mouthpiece. 2. If message persists and subject appears to be blowing properly contact the crime lab.
Any jumbled characters or status messages not described above.	<ol style="list-style-type: none"> 1. If status message persists contact the crime lab (breath test supervisors)

Instrument problems with no status messages	
External Standard Leaks	<ol style="list-style-type: none"> 1. Unscrew and reinsert external standard cylinder. 2. If leak persists contact the crime lab
Test Strip Won't Print	<ol style="list-style-type: none"> 1. Make sure the printer is set up properly and attached to the instrument. 2. Contact the crime lab.
Display Frozen	<ol style="list-style-type: none"> 1. Reboot Instrument 2. If problem persists contact crime lab
Subject has to blow too hard or too easy to get a breath test.	<ol style="list-style-type: none"> 1. Perform a non-drinking subject test. If instrument <u>seems</u> to be accepting/not accepting the sample properly, contact the crime lab
RFI/Interference/Invalid Samples occurs with unusually high frequency	<ol style="list-style-type: none"> 1. Contact the crime lab

Alaska Scientific Crime Detection Laboratory

Alaska Breath Test Operator and Supervisor Manual

Issued: 05/12/2016

Version: ABTOSM 2016 R0

Effective: 05/16/2016

Status: Active

For breath test operators experiencing issues with their instruments the first step should be to contact a breath test supervisor. If a breath test supervisor is unavailable then contact the crime lab for assistance.

If these suggestions do not resolve the problem or other problems exist please contact the crime lab at:

Breath Alcohol Program
(907) 269-5740
dps.scdl.toxicology@alaska.gov

Alaska Scientific Crime Detection Laboratory

Alaska Breath Test Operator and Supervisor Manual

Issued: 05/12/2016

Version: ABTOSM 2016 R0

Effective: 05/16/2016

Status: Active

SECTION 8

REFERENCES

Alaska Criminal and Traffic Law Manual

Medical-Legal Aspects of Alcohol, Garriott, Fourth Edition, 2003

Product Overview DMT, National Patent Analytical Systems, Inc., 2010

Alaska Scientific Crime Detection Laboratory

Alaska Breath Test Operator and Supervisor Manual

Issued: 05/12/2016
Effective: 05/16/2016

Version: ABTOSM 2016 R0
Status: Active

SECTION 9

STATUS CODES

Status Code	Status Message
0	Communication Error
1	Communication Error
2	Communication Error
3	Communication Error
4	Communication Error
5	User Abort
6	Pump Error
7	Filter 1 Won't Zero
8	Filter 2 Won't Zero
9	Filter 3 Won't Zero
10	Ambient Fail
11	Standard Out of Range
12	Simulator Time Out
13	Simulator Temp High
14	Simulator Temp Low
15	Simulator Temp Unknown
16	Blank Error
17	Internal Standard Error
18	Invalid Sample
19	Interference Detected (External Standard)
20	Detector Overflow

Status Code	Status Message
21	Sample Chamber Temp High
22	Sample Chamber Temp Low
23	RFI Detected
24	Barometer Error
25	Breath Tube Temp High
26	Breath Tube Temp Low
27	Incomplete Sample
28	Filter Wheel Error
29	Sample Agreement Error
30	Suck Back Error
31	Calibration Error
32	Undefined Error
33	Diagnostic Failed
34	Fuel Cell Disagreement
35	Fuel Cell Error
36	Tank Pressure Too Low
37	Gas Flow Error
40	Static Analysis Error
100	Standard Deviation Error
101	Maximum Attempts Exceeded
102	Interference Detected (Subject Sample)

TEST CODES

I	Incomplete
V	Invalid
X	Interference Detected
R	Subject Refused

Please note this is a list provided by the manufacturer. Not all codes may be applicable to Alaska instruments.

Alaska Scientific Crime Detection Laboratory

Alaska Breath Test Operator and Supervisor Manual

Issued: 05/12/2016

Version: ABTOSM 2016 R0

Effective: 05/16/2016

Status: Active

SECTION 10

REVISION HISTORY

ABTOSM 2016 R0	BATPM 2016 R0	Location	Revision made
		Title	Changed Title to “Alaska Breath Test Operator and Supervisor Manual” from “Breath Alcohol Testing Program Manual.”
		Throughout	Changed breath alcohol discipline to breath alcohol program and corrected capitalization of breath alcohol program and crime lab.
2	2	Section 1	Updated scientific director information.
31	31	Section 7 Under Instrument Location	Added “The RFI detector sensitivity is verified by the breath alcohol program during instrument certification. The breath hose should not be replaced in the field because the RFI sensitivity for the instrument could change.”
40	40	Section 9	Added Test Codes Table
-	-	All	The Forensic Alcohol Supervisor changed to the Chemistry Supervisor and this is reflected in the issuing authority of this document.